

INSTALLATION MANUAL

FOR HALOCARBON GAS SYSTEM

HFC 227EA – HFC 125 – HFC 23



www.atapars.com

آدرس سایت:

info@atapars.com

آدرس پست الکترونیکی:

+۹۸۲۱ - ۹۱۰۹۲۰۷۶

تلفن دفتر مرکزی:

+۹۸۹۳۹۹۶۰۳۸۰۰

تلفن همراه:



www.atapars.com

آدرس سایت:

info@atapars.com

آدرس پست الکترونیکی:

+۹۸۲۱ - ۹۱۰۹۲۰۷۶

تلفن دفتر مرکزی:

+۹۸۹۳۹۹۶۰۳۸۰۰

تلفن همراه:

آبادگستر تاسیسات ایرانیان (آتا)
Abad Gostar Tasalat Iranian Co., LTD

Contents

1	Introduction	4
1.1	General information	4
1.2	Scope and purpose of manual	5
1.3	Standards and Code of practice	6
1.4	Transport and material management	6
1.5	Preliminary control and operations	10
2	System description	11
2.1	Single cylinder system	11
2.2	Multiple cylinders system	12
2.3	Components description	13
2.3.1	Cylinder	13
2.3.2	Discharge valve	14
2.3.3	Solenoid actuator	17
2.3.4	Removable pressure gauge with supervisory pressured switch	17
2.3.5	Pilot flex hose	19
2.3.6	Discharge flex hose	20
2.3.7	Check valve	21
2.3.8	Discharge manifold	21
2.3.9	Pipe line pressure switch	22
3	Mechanical and electrical installation	24
3.1	Procedure of installation	24
3.2	Cylinders installation	28
3.2.1	General consideration for cylinder installation	28
3.2.2	SINGLE cylinder installation	29
3.2.3	SINGLE-ROW multiple cylinders installation	31
3.3	Discharge flex hose installation	33
3.4	Discharge manifold installation	34
3.4.1	Discharge manifold placement for multiple cylinders system	34
3.5	Removable pressure gauge with supervisory pressured switch assembly installation	36
3.6	Electrical/manual solenoid actuator installation and pneumatic connection	37
3.7	Pilot pneumatic connection	39
3.7.1	Single cylinder	39
3.7.2	Pilot and slave Cylinder	40
4	Pipes, fittings, brackets and nozzles installation	41
5	Mechanical system acceptance	42
5.1	Testing procedures	42
Revised 05/2010	Protected area volume	44



www.atapars.com

آدرس سایت:

info@atapars.com

آدرس پست الکترونیکی:

+۹۸۲۱ - ۹۱۰۹۲۰۷۶

تلفن دفتر مرکزی:

+۹۸۹۳۹۹۶۰۳۸۰۰

تلفن همراه:

5.1.2 Protected area integrity	44
5.1.3 Design correspondence.....	45
5.1.4 Pipeline fixing	45
5.1.5 Pipeline locking	45
5.1.6 Pneumatic circuit.....	45
5.1.7 Functional Test	46
6 Extinguishing system start up.....	49
6.1 Electrical-Mechanical connection Solenoid Actuator	49

1 Introduction

1.1 General information

These systems, described in this manual, use the halocarbon chemical agent and consist of two basic components. The basic components used for these system are:

- ✚ Storage/Distribution components;
- ✚ Detection and alarm devices and control panels.

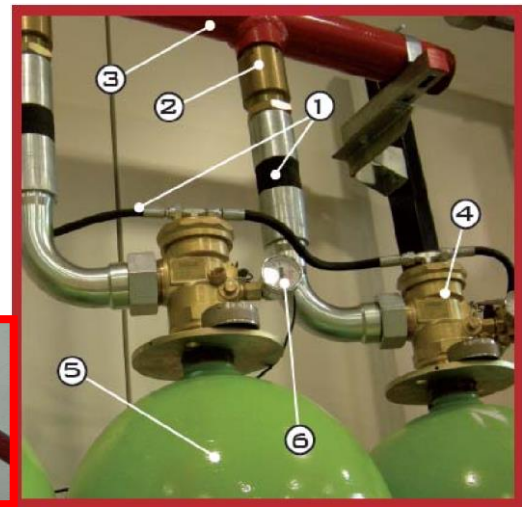
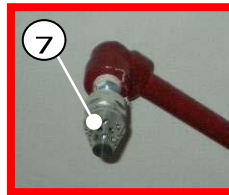

Fig.1.1 List of mechanical components

Storage/Distribution components

Table 1.1 List of components

	Standard Ref.	List of components
1	EN 12094-8	Connectors
2	EN 12094-13	Non-return Valve and check Valve
3	PED 97/36/CE	Discharge Manifold
4	EN 12094-4	Discharge Valve and its actuator
5	TPED 99/36/CE	Cylinder
6	EN 12094:10	Removable pressure gauge with supervisory pressured switch and pressure switch
7	///	Nozzle

Detection and alarm devices and control panel

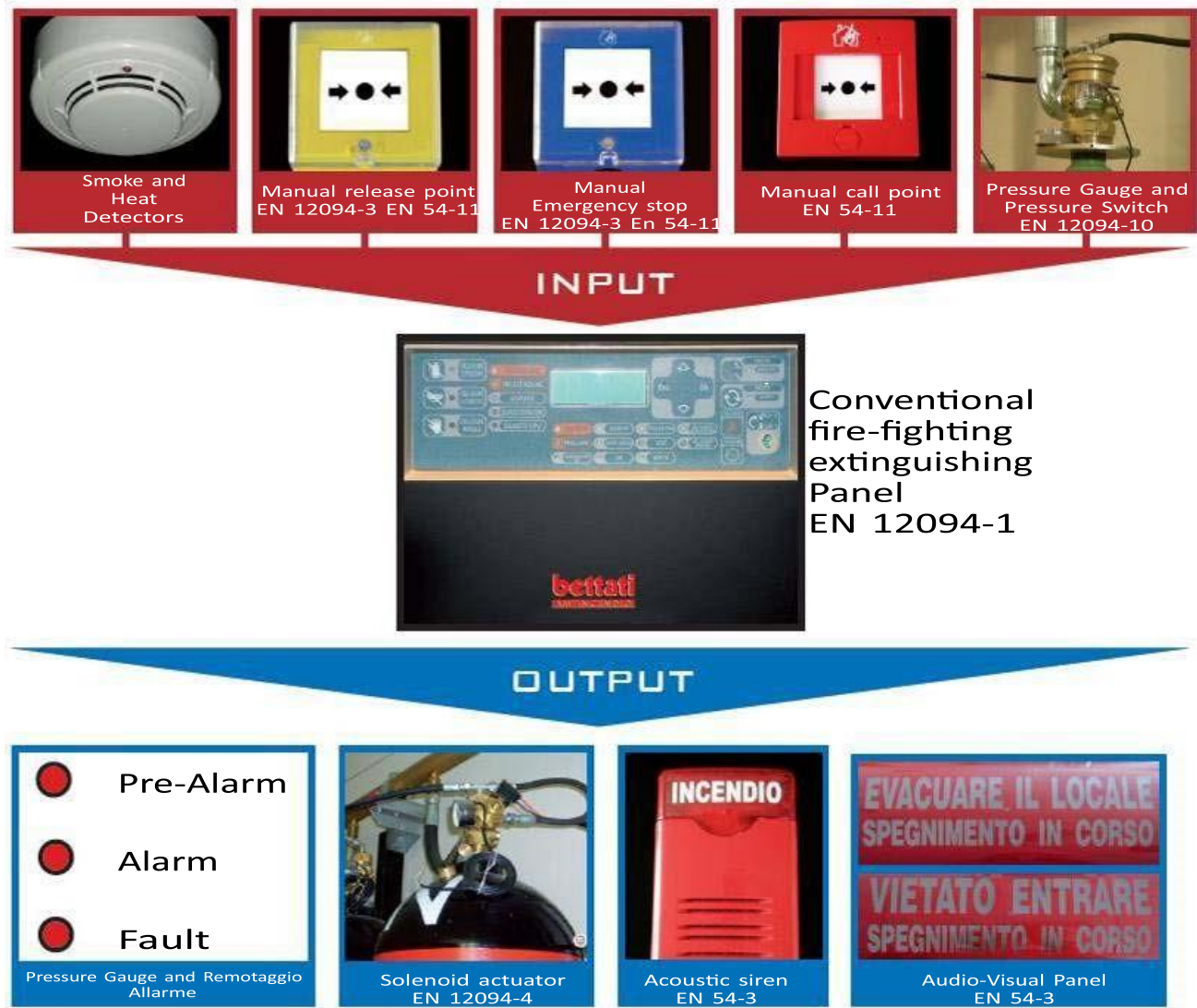





Fig.1.2 List of components of the detection system

1.2 Scope and purpose of manual

This manual is a comprehensive guide containing all recommendations necessary to install the Halocarbon HFC125, HFC227EA and HFC23 Gas Extinguishing Systems supplied by Bettati Antincendio srl.



Discharge of a unsecured and disconnected cylinder could be extremely dangerous and may result in injury or death, and/or damage the property.

	<p>NEVER connect the pilot or slave discharge head, solenoid pilot valve assembly or flexible pilot connectors to the cylinders, or have the solenoid pilot valve wired to the system's electrical control UNTIL the cylinder has been properly secured in the cylinder rack and the discharge connection fittings connected to the system piping.</p>
	<p>High-pressure-stored gasses are involved in the installation of this system</p>
	<p>The installation of the system must be complying with the requirement of this manual</p>
	<p>The installation shall be done ONLY by recommended Bettati Antincendio trained technician</p>

1.3 Standards and Code of practice

Systems that use extinguishing Halocarbon HFC125, HFC227EA and HFC23 agents are designed according to these standards:

- EN 15004-1:2008 "Fixed firefighting systems. Gas extinguishing systems. Part 1: Design, installation and maintenance".
- EN 15004-4:2008 "Fixed firefighting systems. Gas extinguishing systems. Part 4: Physical Properties And System Design Of Gas Extinguishing Systems For HFC 125 Extinguishant".
- EN 15004-5:2008 "Fixed firefighting systems. Gas extinguishing systems Part 5: Physical properties and system design of gas extinguishing systems for HFC 227ea extinguishant".
- EN 15004-6:2008 "Fixed firefighting systems. Gas extinguishing systems - Part 6: Physical properties and system design of gas extinguishing systems for HFC 23 extinguishant".

Components used in the system that use extinguishing Halocarbon HFC125, HFC227EA and HFC23 agents meet the requirements of the following standards:

- EN 12094-4:2004 "Fixed firefighting systems. Components for gas extinguishing systems. Requirements and test methods for container valve assemblies and their actuators".
- EN 12094-5:2004 "Fixed firefighting systems. Components for gas extinguishing systems. Requirements and test methods for high and low pressure selector valves and their actuators".
- EN 12094-6:2006 "Fixed firefighting systems. Components for gas extinguishing systems. Requirements and test methods for non-electrical disable devices".
- EN 12094-8:2006 "Fixed firefighting systems. Components for gas extinguishing systems. Requirements and test methods for flexible connectors".
- EN 12094-10:2004 "Fixed firefighting systems - Components for gas extinguishing systems. Requirements and test methods for pressure gauges and pressure switches"
- EN 12094-13:2002 "Fixed firefighting systems. Components for gas extinguishing systems. Requirements and test methods for check valves and non-return valves".

1.4 Transport and material management

Revised 05/2010 For the gas extinguishing cylinder transport it must be used proper means of transport and it must be consulted the MSDS (Material Safety Data Sheet) attached with the technical file.

The cylinder must:

- remain either in the pallets or in the proper containers until the ground placement,



Fig.1.3a Cylinders located on pallets



Fig.1.3b Cylinders placed in a container

- be managed by skilled worker and with proper means,

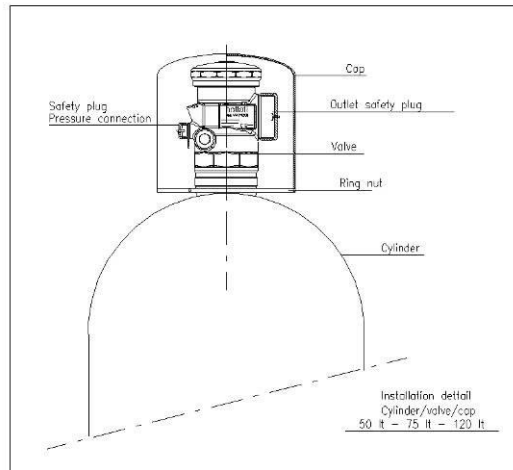
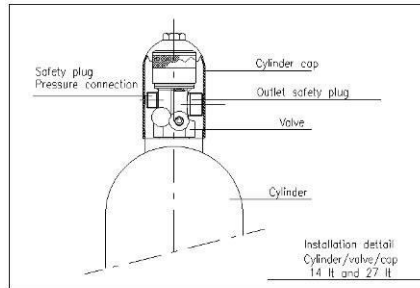

Fig.1.4 Trailer truck to carry cylinders

	<p>During the cylinders handling the valve cap must be correctly placed on the top of the cylinder</p>
---	---

- be placed in a clean and dry place,
- be stored in a sheltered place, protected from heat and atmospheric agents,
- avoid aisles and other high traffic areas where physical damage or tampering is more likely. Containers should never be mounted where the container could potentially be splashed with, or submerged in any liquid,
- cylinder valve cap and all the safety plugs for the pressure connection must be in place when the cylinders are moved or transported,



Revised 05/2010



- Ensure the correct installation position of every cylinder, as shown in the technical drawing.

Every cylinder is provided with specific labels that:  provides the specific information (contained gas, serial number, operating pressure, weight information: tare, gross and agent);

 shows the valve outlet position (this label is useful for the placement of the cylinder, as the valve outlet is hidden by cylinder cap);

 describes the safety information for the handling and storage; describes
 the transport data.

 <small>VIA DISEGNI 4 42100 REGGIO EMILIA (ITALY) Tel. 0522/68711 Fax 0522/71102 E-mail: info@bettatiantincendio.it</small>			
SISTEMI GAS HALOCARBON			
Halocarbon Gas System			
CARICATA CON			
Filled with			
PRESSURIZZATA CON	NITROGEN @		bar
Pressurized with			
MATRICOLA/Serial no.			
PRESSIONE DI CARICA @ 22°C		bar	
Filling pressure @ 22°C			
CAPACITA'/Capacity		Litre	
TARA/Tare		Kg	
PESO VALVOLA, PESCANTE E CAPPELLOTTA		Kg	
Valve, dip tube and cap weight			
PESO CARICA		Kg	
Filling Weight			
PESO LORDO		Kg	
Gross Weight			

Cylinder label

**HIGH PRESSURE CYLINDER FILLED BY GAS
EXTINGUISHING AGENT**

WARNING

FOLLOW THE INSTRUCTION SHOWN IN THIS LABEL AND IN THE
INSTALLATION AND MAINTENANCE MANUAL
KEEP IN GOOD CONDITION THIS LABEL, DO NOT REMOVE, COVER OR
DAMAGE IT

DO NOT KEEP THE CYLINDER UNDER DIRECT SOLAR RADIATION AND
HOWEVER AT TEMPERATURE HIGHER THAN 60°C

DO NOT MOVE OR HANDLING THE CYLINDER WITHOUT THE CYLINDER SAFETY CAP

 **ATTENTION**

Remove the cylinder cap and the antirecoil cap after the cylinder
installation

INSTALLATION

In order to avoid an accidental gas discharging DO NOT install the solenoid actuator on
the valve before this operations:

1. Make sure the cylinder is correctly fixed
2. Make sure the discharge hose is correctly connected with the cylinder and the manifold
3. Make sure the pneumatic connect is correctly installed and checked
4. Make sure there are not any leakages in the solenoid actuator connection before mounting the flex hose

MAINTENANCE

Before making any operation:

1. Do not break the seal and do not remove the safety pin on the solenoid actuator
2. Remove the coil of the solenoid actuator in order to avoid accidental gas discharging

For further information consult the installation or maintenance manual or contact:

Via Disegni, 4 42100 Reggio Emilia
Tel 0522/68711 - Fax 0522/71102 - E-mail: info@bettatiantincendio.it

Safety label
Transports tag



www.atapars.com

info@atapars.com

+۹۸۲۱ - ۹۱۰۹۲۰۷۶

+۹۸۹۳۹۹۶۰۳۸۰۰

آبادگستر تاسیسات ایرانیان (تآ)
Abad Gostar Tasilat Iranian Co., LTD

آدرس سایت:

آدرس پست الکترونیکی:

تلفن دفتر مرکزی:

تلفن همراه:



Valve outlet label

Fig.1.6 Cylider's



tags and labels

1.5 Preliminary control and operations

- ✚ Check that the cylinders support base (especially in case of floor or underfloor voids placement) and the entire structure can support the total loads shown in the following tables (table 1.2);
- ✚ Make a visual checking of the material, ensuring that the quantity of the items match the quantity reported on the data sheet and that it has got the technical specifications reported on the manual “Engineered System”;

All the other materials must be stored in a shelter place, protected from the atmospheric agents, in order to prevent any damage.

	The cylinder valve cap can be removed ONLY after the installation of the cylinders.
---	--

	In order to avoid accidental discharge, the connection between pilot flex hose and the solenoid actuator (see figure 2.1 in the next paragraph, components n° 6 and n° 13) must be done ONLY after the test.
---	---

The cylinders and the accompanying hardware will be supplied with the necessary accessory in according with Bettati Antincendio standard.

The cylinder installation shall be wall-mounted; in order to do so a suitable place must be found. The brackets and the rawplugs used for the installation must support the total load. Normally the cylinder should be placed in a dry and well-ventilated place in order to avoid corrosion and usury phenomena.

Execute the following control procedure, in case of not correspondence with the original design, inform Bettati Antincendio before the installation beginning.

Capacity (L)	External diameter (mm)	Length (mm)	Weight (Kg)
14	168	800	17
27	203	1020	25
50	269	1080	46
75	360	1030	65
120	352 ₃	1520 ³ 1470 ⁴	61 ³
	360 ⁴		119 ⁴
180	406	1780	175
200 _{1,2}	400	1570	///
1. Certification in progress			
2. Welded cylinder, work pressure 42 bar, test pressure 90 bar			
3. only for HFC227ea – HFC125			
4. only for HFC23			

Table.1.2 Dimensions and weights of the cylinders

2 System description

The fire-fighting gas extinguishing system HFC227ea, HFC125 and HFC23 can be subdivided in three different typologies:

- Single cylinders
- Multiple cylinders,

2.1 Single cylinder system

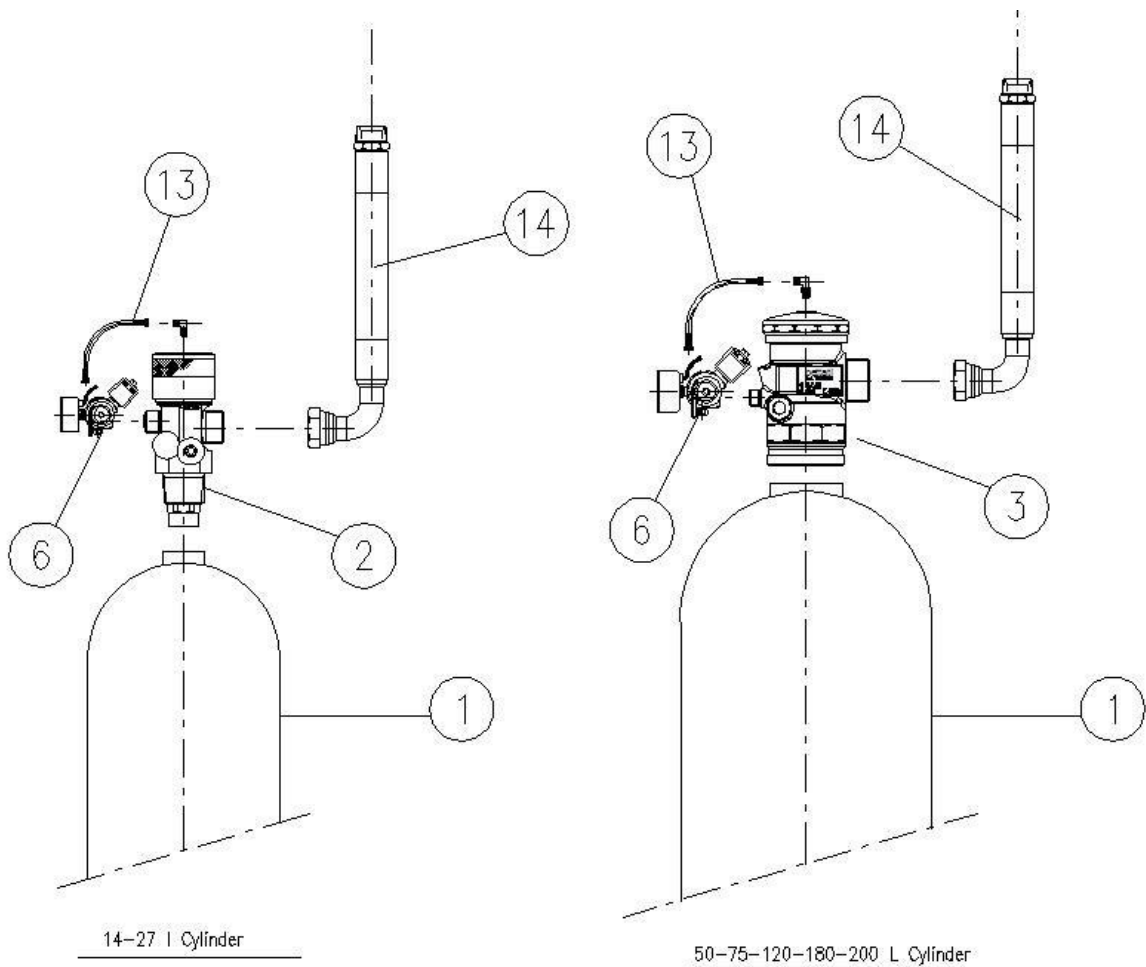

Fig.2.1 Single cylinders

1	Cylinder filled with halocarbon gas and pressurized by nitrogen at 42 bar (for HFC125, HFC 227 EA)
---	--

2	Halocarbon gas valve with ¾" outlet and safety plug (14 L and 27 L)
3	Halocarbon gas valve with 2" outlets and safety plug (50 L, 75 L, 120 L, 180 L, 200 L)
6	Manual solenoid actuator composed by: solenoid pilot valve 24 Vcc, manual swivel actuator, removable pressure gauge with supervisory pressured switch, electric contacts pressure gauge (N.O.), bleeder valve
13	Pilot Flex hose
14	Discharge flex hose 3/4" – 1"1/2 – 2"

The numbers make reference to the data sheets Bettati Antincendio srl

Table.2.1 Components list of Single cylinders system

2.2 Multiple cylinders system

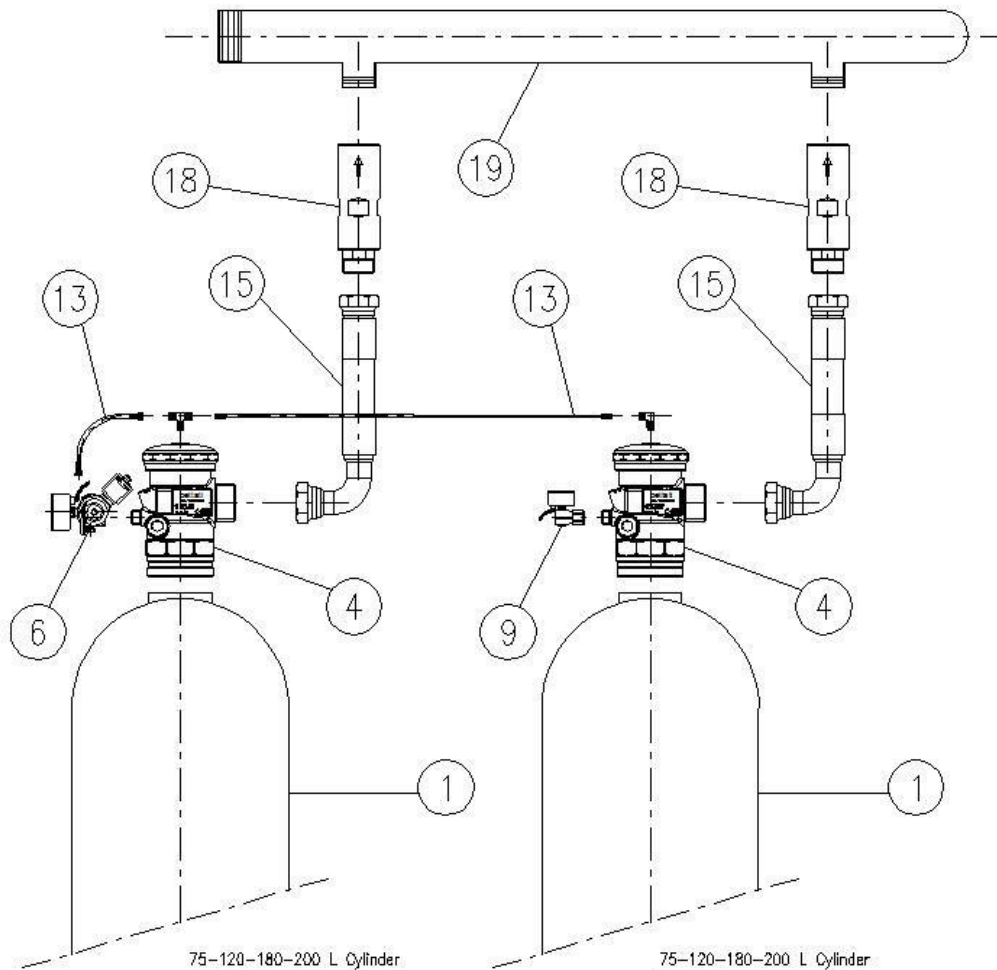

Fig.2.2 Multiple Cylinders

1	Cylinder filled with halocarbon gas and pressurized by nitrogen at 42 bar (for HFC125, HFC 227 EA)
4	Halocarbon gas valve with 2" outlet and safety plug (75 L, 120 L, 180 L and 200 L cylinders)

6	Manual solenoid actuator composed by: solenoid pilot valve 24 Vcc, manual swivel actuator, pressure gauge, electric contacts pressure gauge (N.O.), bleeder valve
9	Removable group with electric contacts pressure gauge (N.O)
13	Pilot Flex hose
15	Discharge flex hose 1" 1/2 - 2"
18	Non-return valve 2"
19	Gas manifold made of steel sch. 40 type
The numbers make reference to the data sheet Bettati Antincendio srl	

Table.2.2 Components list of Multiple Cylinders system

2.3 Components description

-

The following sections describe the components of the Bettati Antincendio srl system previously listed. For more details contact Bettati Antincendio staff at this address:



2.3.1 Cylinder

The seamless steel cylinders are manufactured according to EN 1964-1 : 1999/36/CE T-PED.

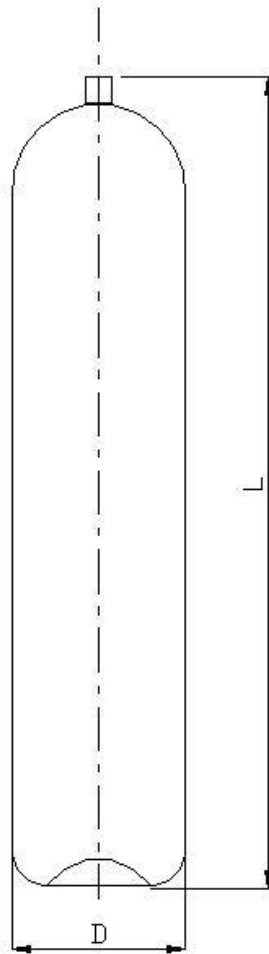

Capacity (L)	External diameter (mm)	Length (mm)	Weight (Kg)	Neck thread (inch)	Test pressure (bar)	Working pressure (bar)
14	168	800	17	1" NPT G	300	200
27	203	1020	25	1" NPT G	300	200
50	269	1080	46	2"1/2 NPT G	250	166
75	360	1030	65	2"1/2 NPT G	250	166
120	360* 352*	1470 1520	119 61	2"1/2 NPT G 2"1/2 NPT G	300 100	200 150
180	406	///	///	2"1/2 NPT G	300	200
200	400	1570	///	2"1/2 NPT G	300	200

Halocarbon gas	Color body	Color ogive
HFC 227 ea	red - RAL3000	green - RAL6018
HFC 23	red - RAL3000	green - RAL6018
HFC 125	red - RAL3000	green - RAL6018

Fig 2.3 Cylinder characteristics

2.3.2 Discharge valve

The seamless steel cylinders are manufactured according to EN 1964-1 : 1999/36/CE T-PED

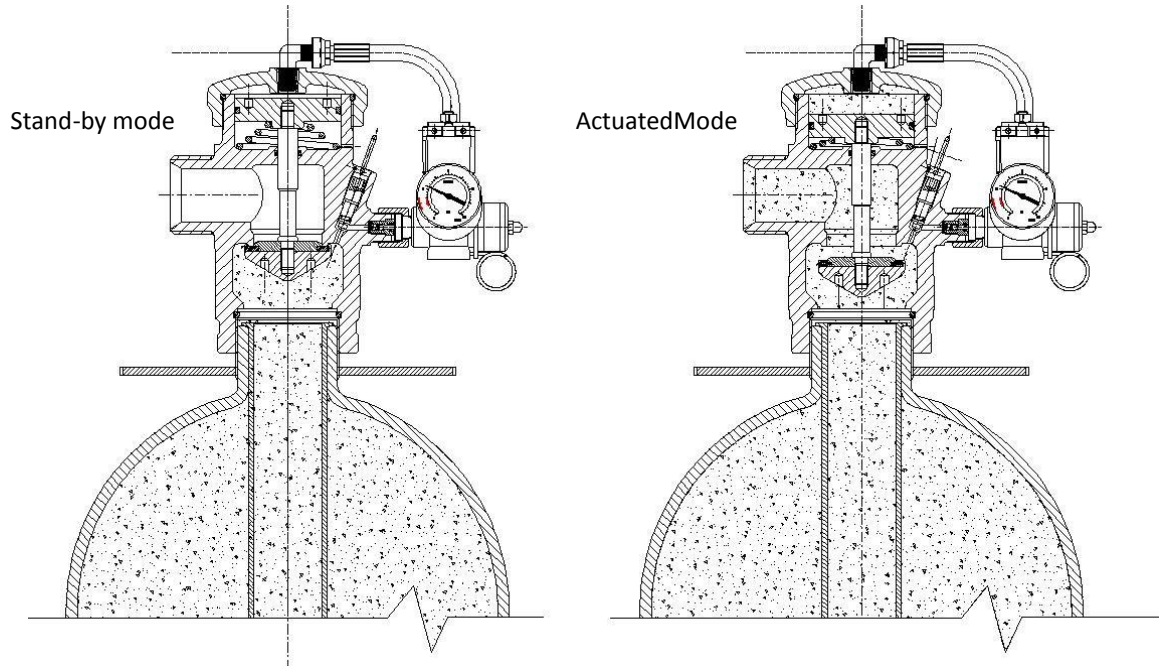

Fig.2.4-a Discharge valve

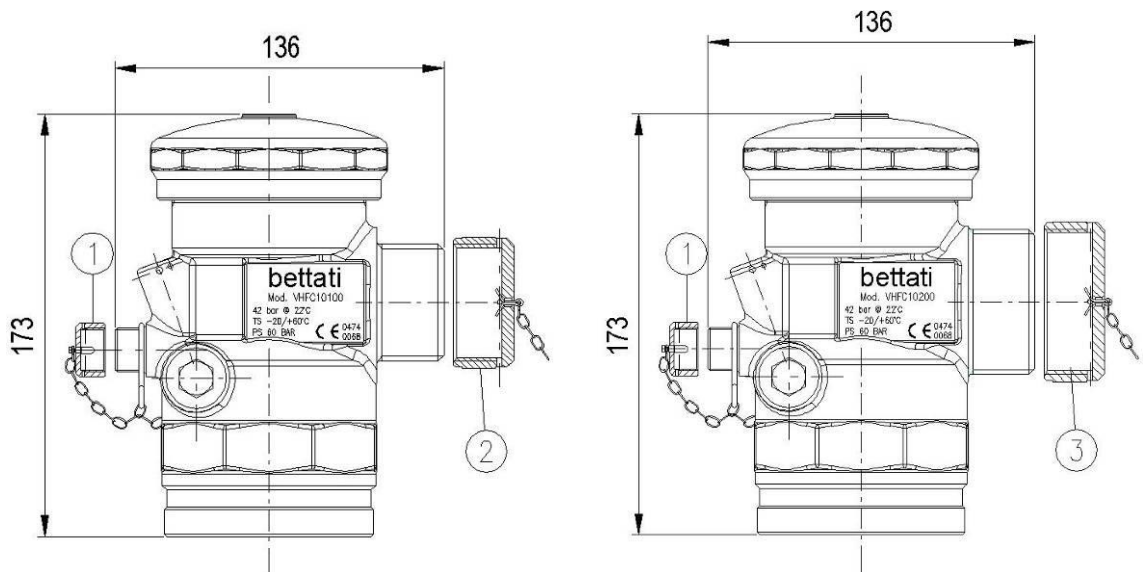

Fig.2.4-b Discharge valve, inlet 2 1/2-outlet 1 1/2 for 50 and 75 L single cylinders

Fig.2.4-c

1	Protection cap pressurized connection
2	Antirecoil cap \varnothing 1 1/2
3	Antirecoil cap \varnothing 2"
4	Antirecoil cap \varnothing 3/4"

Discharge valve,

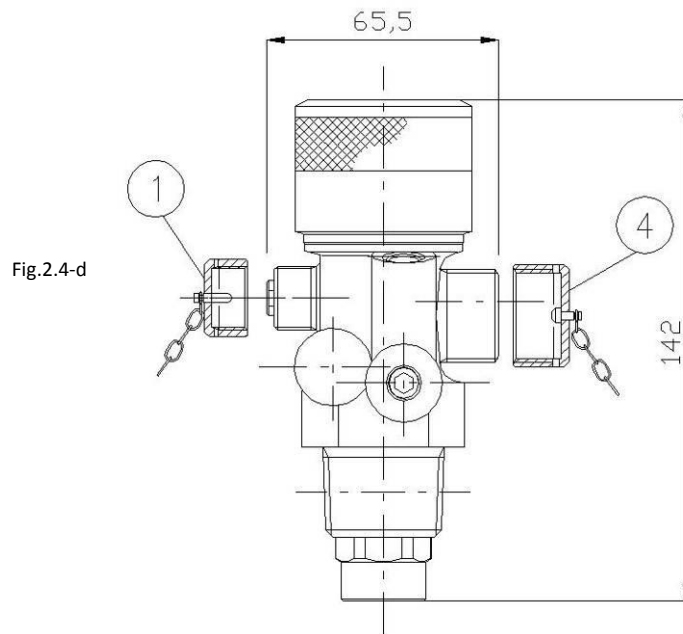

Fig.2.4-d

Table.2.3 Caps list of the valves

Discharge valve, inlet 1" - outlet 3/4" for 14 and 27 L single cylinder

A pressure operated cylinder valve having a forged brass body and cap is attached to the 14 lt and 27 lt cylinders neck. It is activated by means of an operating piston at the top.

2.3.3 Solenoid actuator

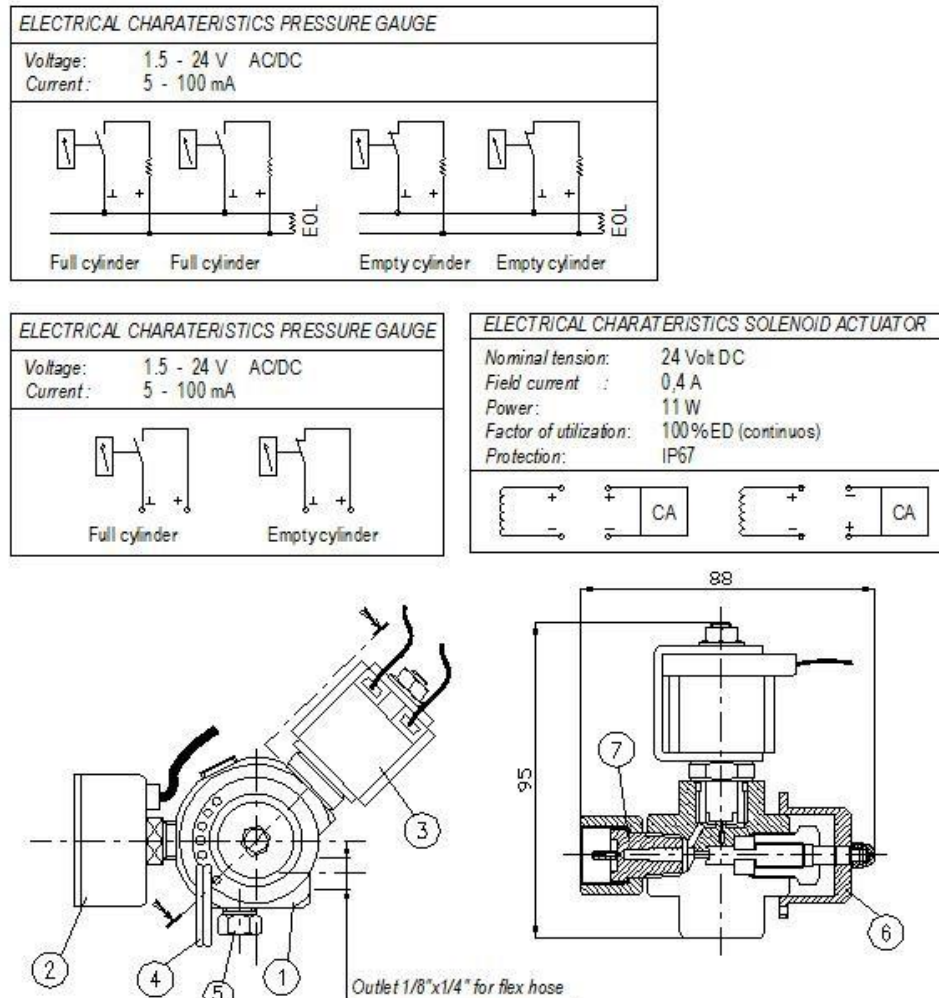

Fig.2.5 Solenoid actuator

1	Body
2	Pressure gauge with supervisory pressured switch 0-100 bar ∅40
3	Solenoid pilot valve 24 Vcc 11 W
4	Safety pin
5	Bleeder valve
6	Manual swivel actuator
	Swivel nut (connection to valve)

components

The command implementation is certified according to EN 12094-4 and the pressure gauge according to EN 12094-10

This manual solenoid actuator assembly includes pressure gauge, low pressure switch, bleeder valve and adapter with swivel nut.

Table.2.4 List of the solenoid actuator's

	<p>To know which electrical resistance it shall be used for all the electrical connection see the extinguishing panel technical manual which is not include in this documentation.</p>
---	---

2.3.4 Removable pressure gauge with supervisory pressured switch

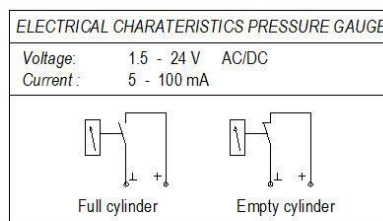
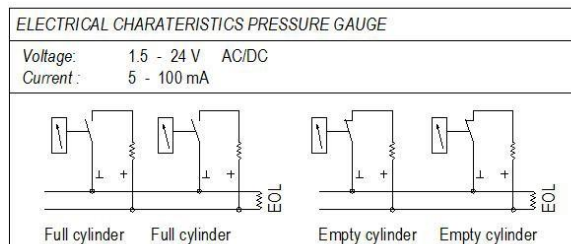
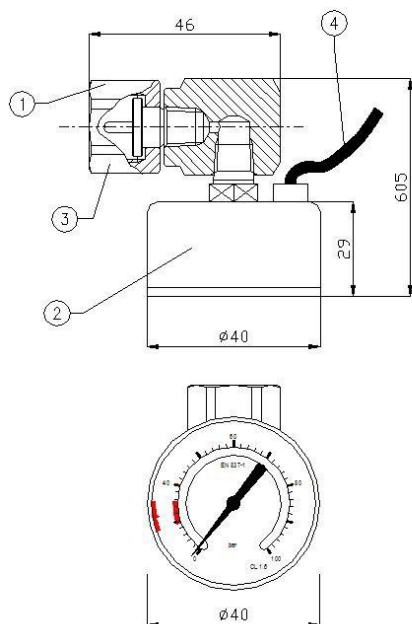



Fig.2.6 Removable pressure gauge with supervisory pressured switch

The gauge is certified according to
UNI EN 12094-10

1	Body
2	Pressure gauge with supervisory pressured switch 0-100 bar \varnothing 40
3	Swivel connection
4	Electrical plug

This unit is required for the slave cylinder to provide a local visual means to determine the pressure within the slave cylinder.

Table.2.5 List of the pressure gauge's components

	<p>To know which electrical resistance it shall be used for all the electrical connection see the extinguishing panel technical manual which is not include in this documentation.</p>
---	---

2.3.5 Pilot flex hose

Internal diameter (inch)	Reinf. outside diameter (mm)	Outside diameter (mm)	Working pressure (bar)	Bursting Test (bar)	Weight (Kg/m)
3/16"	9.5	11.8	415	1650	0.18

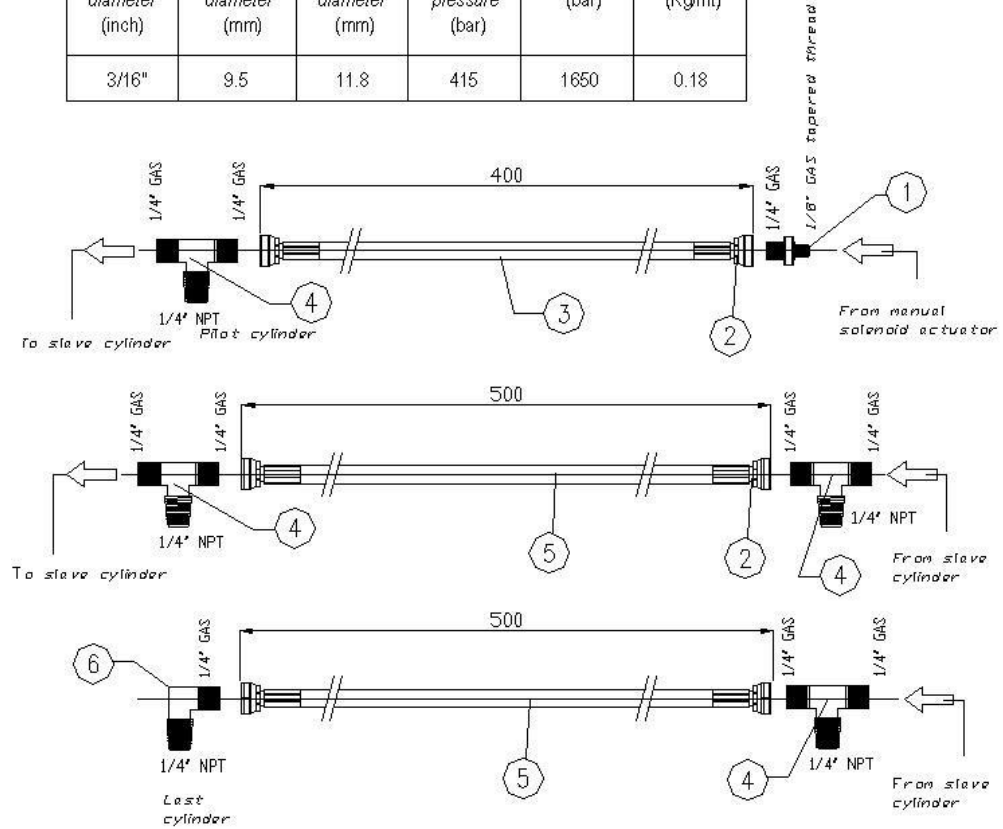

Fig.2.7 Flex hoses

1	Nipples 1/4" GAS x 1/8" GAS tapered thread
2	Swivel nut 1/4" GAS
3	Hose connection actuator - master cylinder 3/16"
4	Tee connection 1/4"
5	Hose connection cylinder - cylinder 3/16"
6	Elbow 1/4"GAS x 1/4"NPT

Table.2.6 List of the flex hoses' components

The flexible connectors are used to interconnect the cylinder valve device.

This 3/16" ID reinforced rubber flex hose has threaded connection to allow interface between components.

The flexible hoses are certified according to UNI EN 12094-8

2.3.6 Discharge flex hose

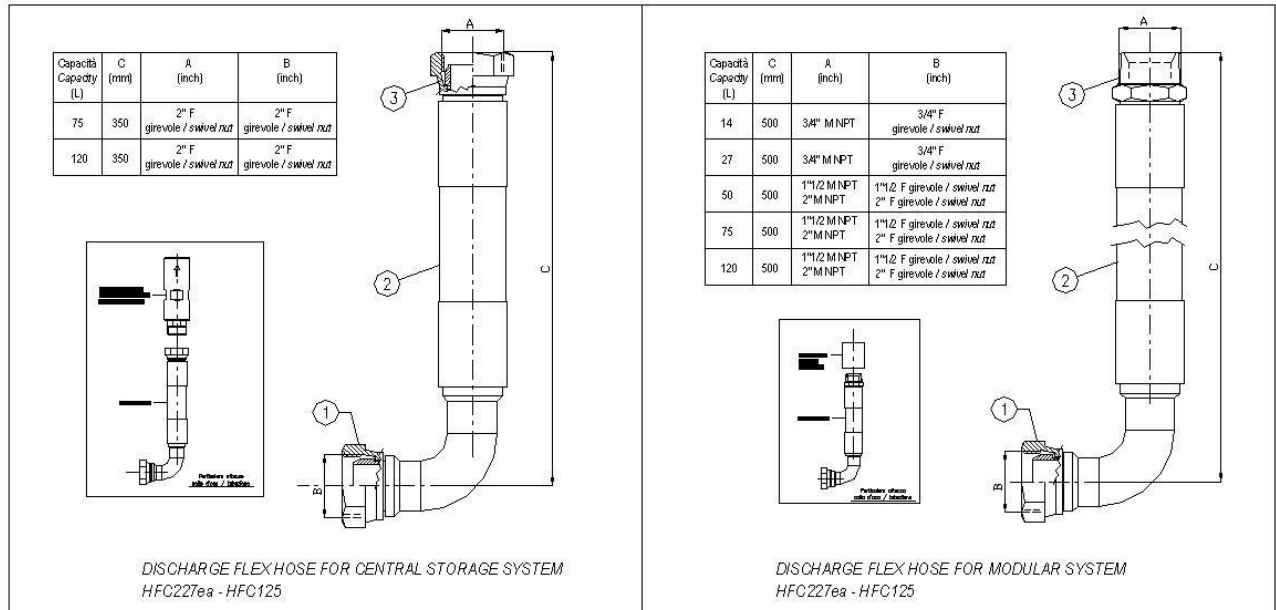

Fig.2.8-a Discharge hoses for HFC227ea HFC125 systems

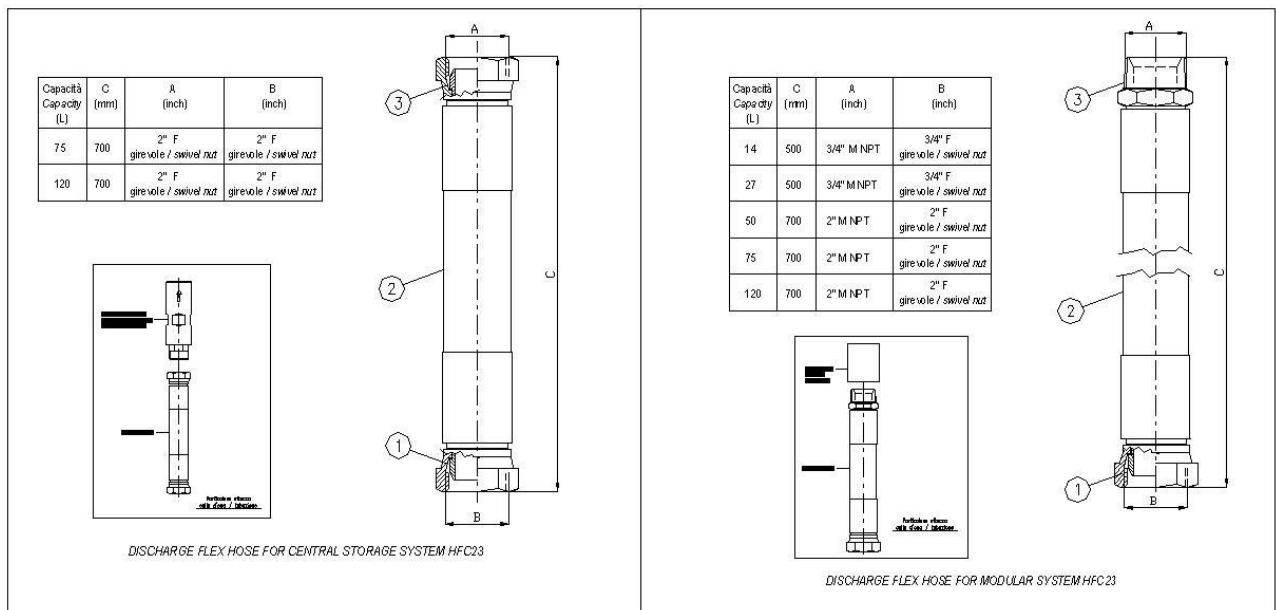

Fig.2.8-b Discharge hoses for HFC23 systems

1	Swivel nut
2	High pressure rubber hose
3	Swivel nut

The flexible

These discharge flex hoses are used to connect the cylinder with the manifold or with the piping system.

Table.2.6 List of the discharge hoses' components

hoses are certified

according to UNI EN 12094-8

2.3.7 Check valve

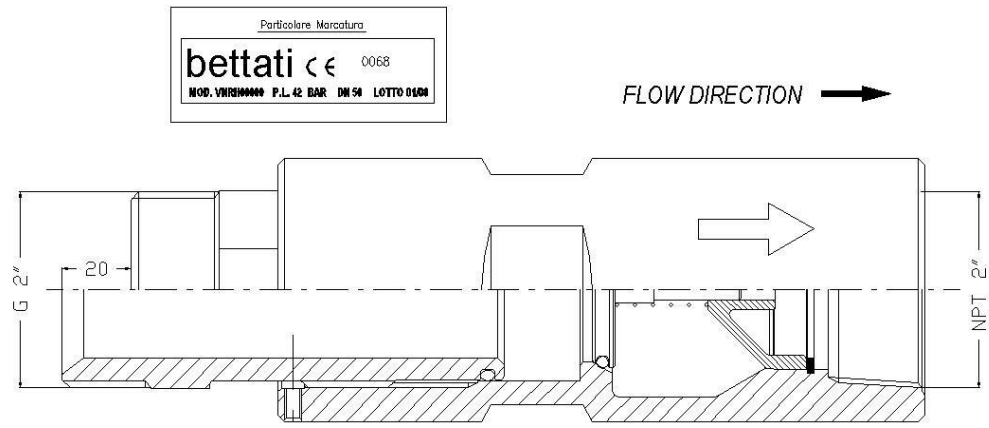
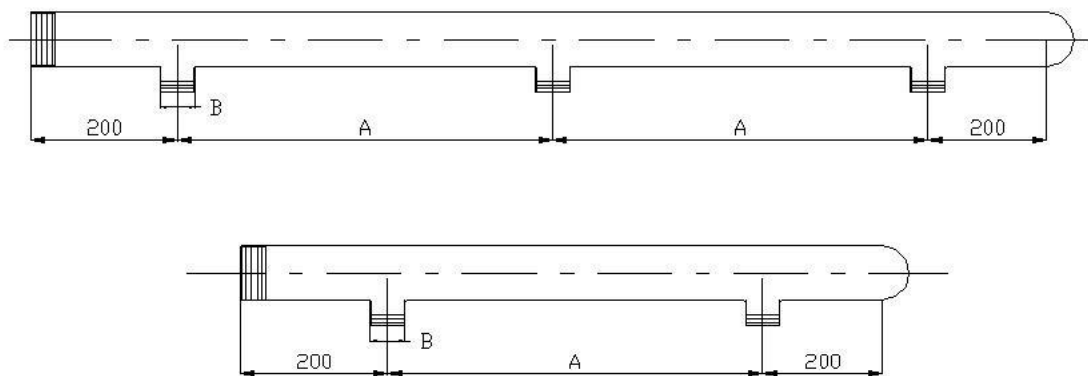

Fig 2.9 Check valve

The check valve is used between the cylinder valve discharge outlet flexible connection and the discharge manifold. It prevents back flow from the manifold in the event that the system is discharged when one or more cylinder are disconnected, such as for weighing or general servicing.

To help the connection between the discharge flex hose and the manifold, the valve is extendable for about 20 mm.

2.3.8 Discharge manifold



Pipe type	HFC125	HFC23	HFC227ea
SCH.40	X		X
SCH.80		X	

Cylinder capacity	A (mm)	B (inch)
75 lt	450	2" M NPT
120 lt	450	2" M NPT

Fig 2.10 Discharge manifolds

The discharge manifold is constructed of welded pipe or fittings and is designed to accumulate the combined flow of two or more cylinders into a common pipe leading into the protected area.

2.3.9 Pipe line pressure switch

The pressure switch is activated by pressure from the agent during discharge. Its function is to advert the control panel in case of system activation specially in case of manual activation. The pressure switch is supplied with a resetting stud.

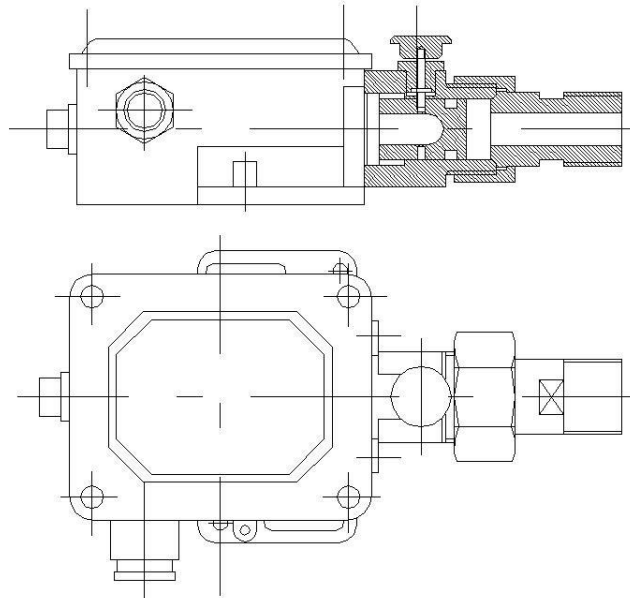
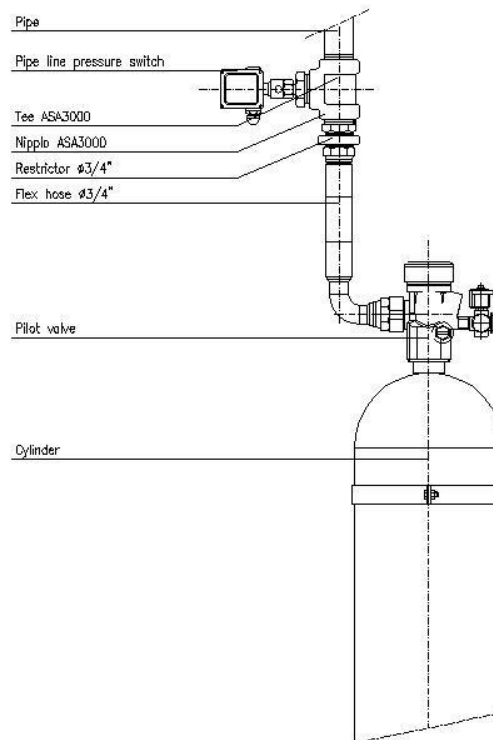

Fig 2.11 Pipe line pressure switch

Single Cylinder system



Nipples, TEE and the fittings adapter are NOT supplied by Bettati Antincendio

Fig 2.12 Mechanical installation of pressure switch in a single cylinder system

To install the device, in single cylinder systems, connect the discharge flex hose to a TEE, not supplied by Bettati Anticendio. In the central position of TEE connect the pressure switch

Multiple Cylinders system

OPTION 1

Fig 2.13 Mechanical installation of pressure switch in a multiple cylinders OP.1

OPTION 2

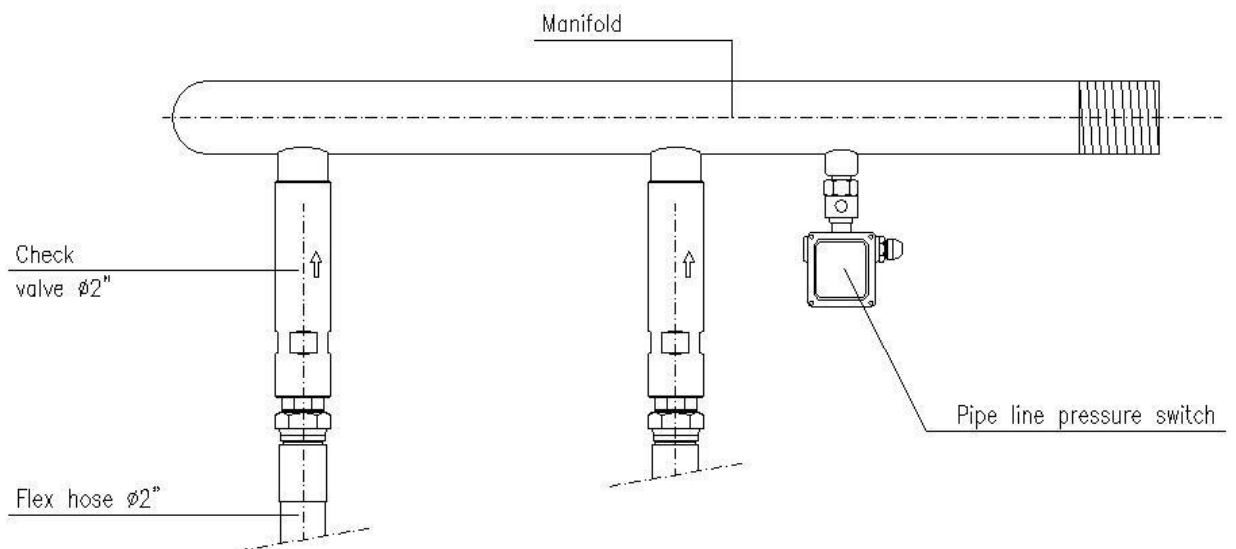

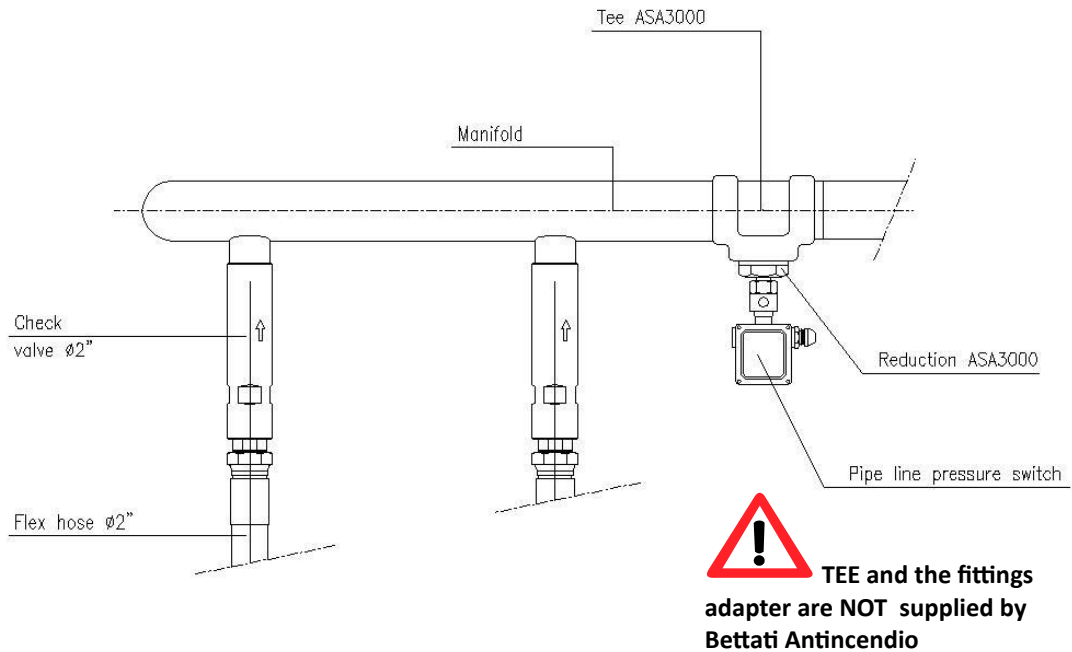



Fig 2.14 Mechanical installation of pressure switch in a multiple cylinders OP.2

Depending on the chosen option it shall be advise Bettati Antincendio in advance. It will provide to adapt the manifold. In fact, Option 1 involves the welding of a component on the manifold that permits the pressure switch installation

	Don't modify the given manifold, the modification would make useless the BETTATI ANTINCENDIO test and the respective certify.
---	--

3 Mechanical and electrical installation

	The installation shall be done ONLY by recommended Bettati Antincendio trained technician
---	--

3.1 Procedure of installation

- | | |
|----------|--|
| 1 | Check the correct cylinders placement and install the cylinder mounting bracket. Place the cylinder (usually the valve outlet, as indicated on the label, is placed on the left) and rotate it toward the wall for about 20° to enable the connection between the discharge hose and the manifold |
|----------|--|

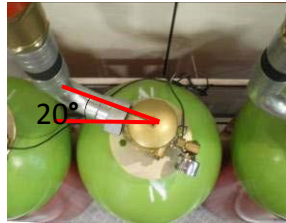

2

Install the discharge flex hose



3

Fix the cylinders and install the manifold and the pipe line pressure gauge



4

Install the **removable pressure gauges** (slave cylinders);



5

Install the **pilot pneumatic connection**, connecting the cylinders with the flex hose



6

Install the **removable electrical/manual solenoid actuator** in the pilot cylinders



7

Install the extinguish gas pipeline. The pipeline shall be made of steel (type schedule according to the pressure) with ASA3000 fittings





www.atapars.com

آدرس سایت:

info@atapars.com

آدرس پست الکترونیکی:

+۹۸۲۱ - ۹۱۰۹۲۰۷۶

تلفن دفتر مرکزی:

آبادگستر تاسیسات ایرانیان (آتا)
Abad Gostar Tasisat Iranian Co., LTD

+۹۸۹۳۹۹۶۰۳۸۰۰

تلفن همراه:

8

Test the extinguishing system following the checking list

Tests description	RESULT
Protect area volume acceptance	
Enclosure check	yes no na
Review of enclosure integrity	yes no na
Visual checking	
Door fan test with gauge staff-----	yes no na
Isower staff-----	yes no na
Review of mechanical components	
Design conformity checking of:	
Cylinders	yes no na
Pipeline	yes no na
Reducers	yes no na
Cylinders and pipe fitting checking	yes no na
Drivens leaking checking -> cylinders, pipeline, nozzle	yes no na
Pneumatic pipeline checking at 3 bar for 10 minutes (loss of pressure lower than 20%)	yes no na
Done with pressure gauge staff	yes no na
Discharge flow checking	yes no na
Preliminary functional test	
Blank test	yes no na
Actual discharge test	yes no na
Provided documentation	
System technical report	yes no na
Material safety data sheet	yes no na
Hydraulic Calculation	yes no na
Working Drawing	yes no na
CE guideline 93/21/CE's declaration of conformity - Marshold	yes no na

SYSTEM INSTALLATION COMPLETE

3.2 Cylinders installation

3.2.1 General consideration for cylinder installation

	<p>The cylinder is pressurized at 42 bar and must be handled carefully. Although the cylinder valve is constructed of heavy forged brass, it could be damaged if the cylinder is dropped. Discharge of an unsecured and disconnected cylinder could be EXTREMELY DANGEROUS and may result injury or death, and or damage to property. The cylinder, cannot be discharge accidentally unless mishandled.</p>
--	--

	<p>Under normal conditions, the cylinder valve cannot be discharge without having the various pilot devices attached and interconnected by the flexible connectors. NEVER connect the manual-pneumatic actuator, solenoid pilot valve assembly, or flexible pilot connectors to the cylinder, or have the solenoid pilot valve wired to the system's electrical controls UNTIL the cylinder has been properly secured in the cylinder rack and the discharge connection fittings connected to the system piping</p>
--	---

	<p>Remove the valve cylinder cap ONLY after the installation of the cylinder.</p>
--	--

During the installation the mounting strap used to fix the cylinder should not be drawn up tight against the cylinder. Some cylinder movement should be permitted while aligning the cylinder valve discharge outlet with the discharge tube. The cylinders fixing is ensured by screwing tight the bolt and nut shown in the figure.

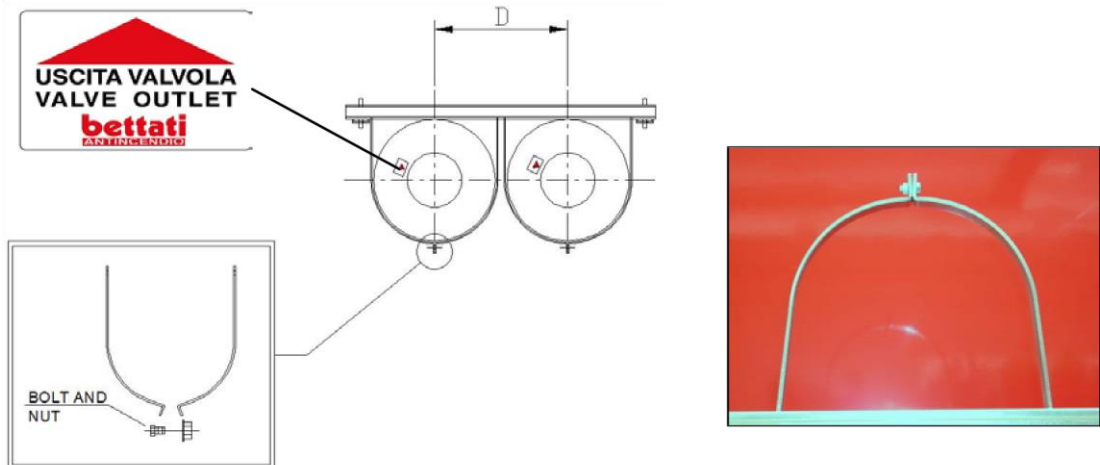

Figure 3.1 Cylinder's mounting straps

	<p>The placement of the valve outlet is indicated by a label placed on the top of the cylinder. Usually the valve outlet is placed on the left, rotate clockwise the cylinder for 20° to enable the connection between the discharge flex hose the manifold.</p>
--	--

In according with this manual , normally the valve outlet is placed on the left. However a different placement on the right, does not compromise the correct installation and the readability of the display as the solenoid actuator assembly or the removable pressure gauge with supervisory pressured switch assembly allows to rotate the measuring instrument. In figure 3.2 it is shown both installations.

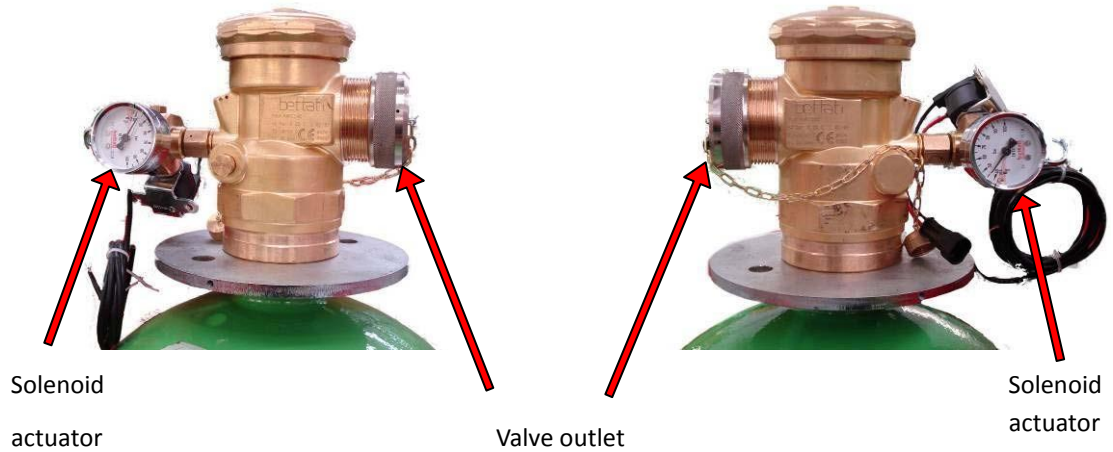

Figure 3.2 Valve's orientation

Once placed the cylinders near the support rotate it toward the wall for about 20° to enable the connection between the discharge hose and the manifold as shown in the figure 3.3.

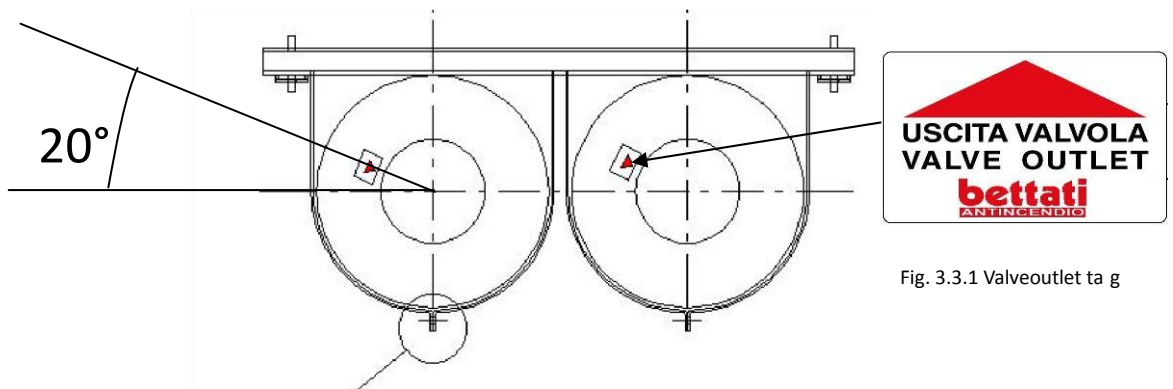

Fig. 3.3.1 Valveoutlet ta g

Figure 3.3 Cylinder's placement

3.2.2 SINGLE cylinder installation

Fix the rear support to a wall; check the quotes show in the figure and in the table and secure the cylinder to a wall with the mounting straps. Be sure that the label, indicating the valve outlet, is in the right position. The mounting straps should not be drawn up tight against the cylinder.

Be careful to the cylinder's capacity, for 14 to 75 l cylinders it is enough just a single rear support, otherwise for 120 l cylinders it is necessary a double rear supports.

SINGLE 14 L and/or 27 L cylinder

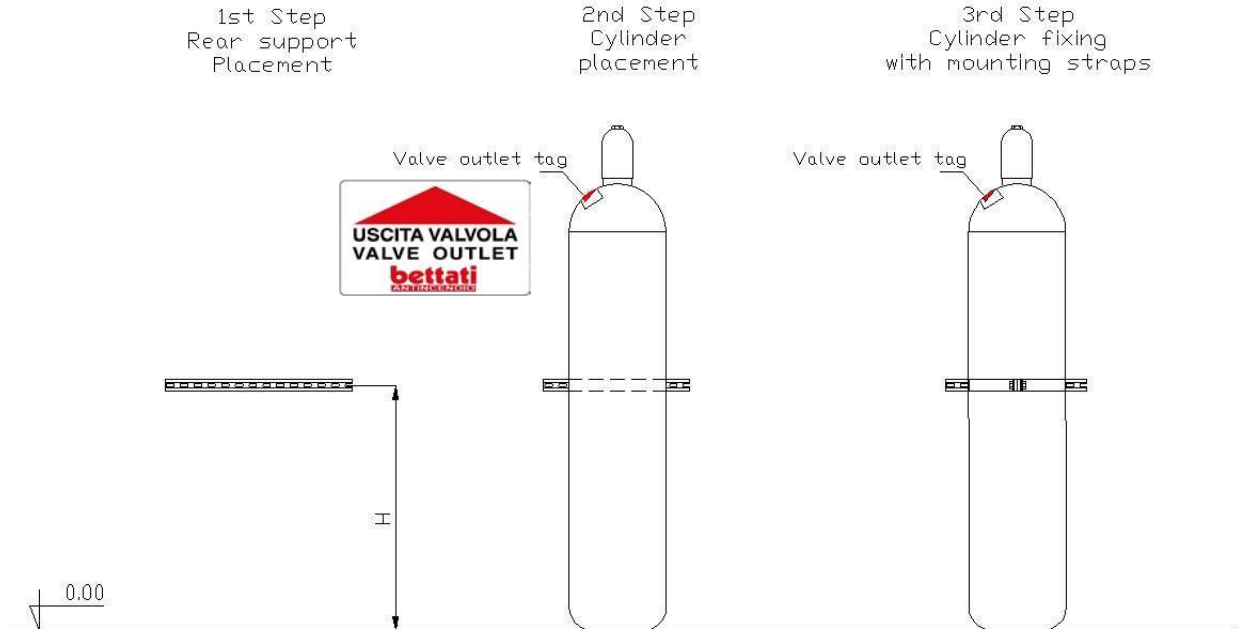

Figure 3.4 Cylinder mounting steps

Capacity (l)	Diameter \varnothing (mm)	Cylinder high (mm)	H support (mm)
14	168	800	500
27	203	1020	700

SINGLE 50 L and/or 75 L cylinder

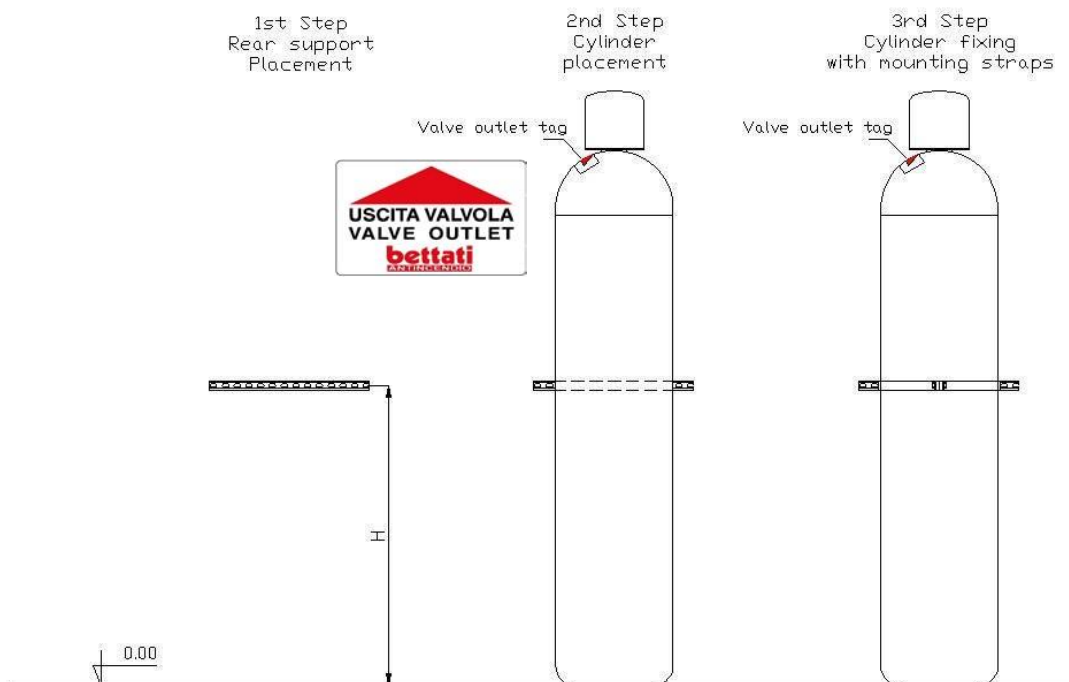

Figure 3.5 Cylinder mounting steps

Capacity (l)	Diameter \varnothing (mm)	Cylinder high (mm)	H support (mm)
50	267	1130	750
75	360	1030	600

SINGLE 120 L cylinder

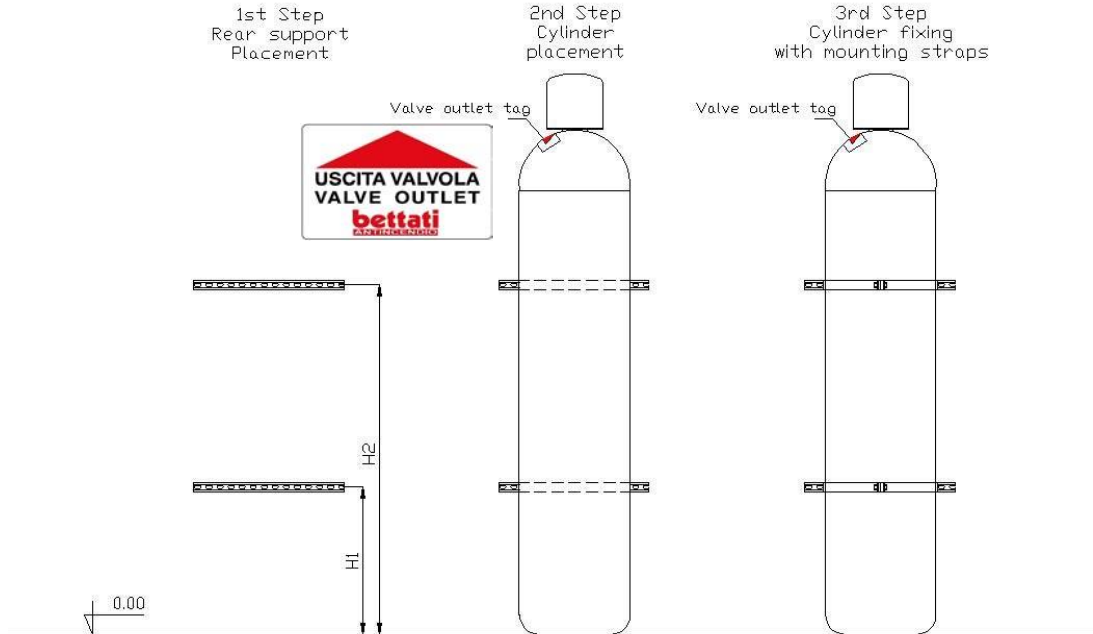

Figure 3.6 Cylinder mounting steps

Capacity (l)	Diameter \varnothing (mm)	Cylinder high (mm)	H1 support (mm)	H2support(mm)
120 ₁	360	1480	750	1100
120 ₂	352	1520	750	1100
1. Only for HFC23				
2. Only for HFC227ea and HFC125				

3.2.3 SINGLE-ROW multiple cylinders installation

Fix the rear support to a wall; check the quotes show in the figure and in the table and secure the cylinder to a wall with the mounting straps. Be sure that the label, indicating the valve outlet, is in the right position. The mounting straps should not be drawn up tight against the cylinder. Some cylinder movement should be permitted while aligning the cylinder valve discharge outlet with the discharge tube.

50 l and/or 75 l cylinder

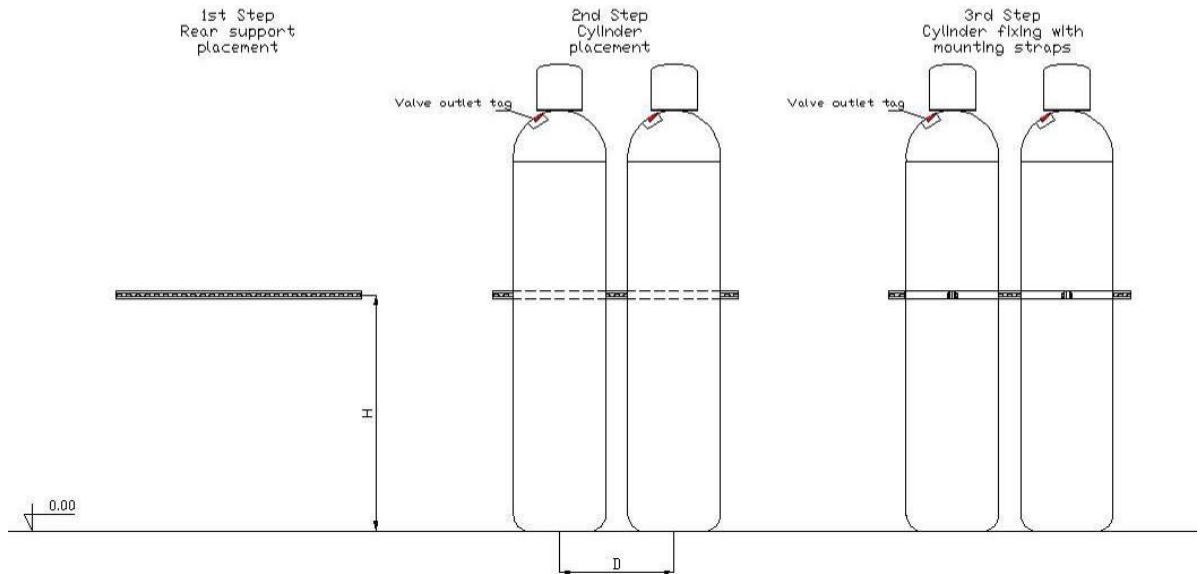

Figure 3.7 Cylinder mounting steps

Capacity (l)	Diameter \varnothing (mm)	Cylinder high (mm)	H support (mm)	Wheel base D (mm)
75	360	1030	500	450

120 l cylinder

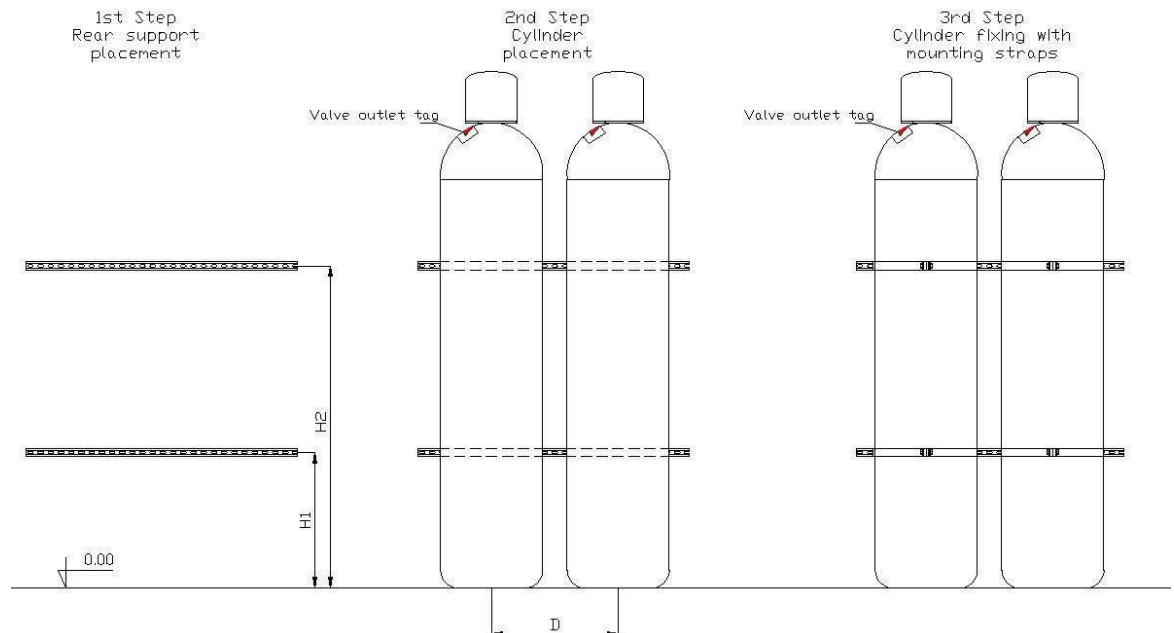

Figure 3.8 Cylinder mounting steps

Capacity (l)	Diameter \varnothing (mm)	Cylinder high (mm)	H1 support (mm)	H2 support (mm)	Wheel base D (mm)
120 ¹	360	1480	750	1100	450
120 ²	352	1520	750	110	450

1. Only for HFC23

2. Only for HFC227ea and HFC125

After the cylinder placement, as describe previously, rotate the cylinder toward the wall for about 20° to enable the connection between the discharge hose and the manifold. It is recommended to hold the valve outlet on the left.

3.3 Discharge flex hose installation

The next step involves the discharge flex hose.

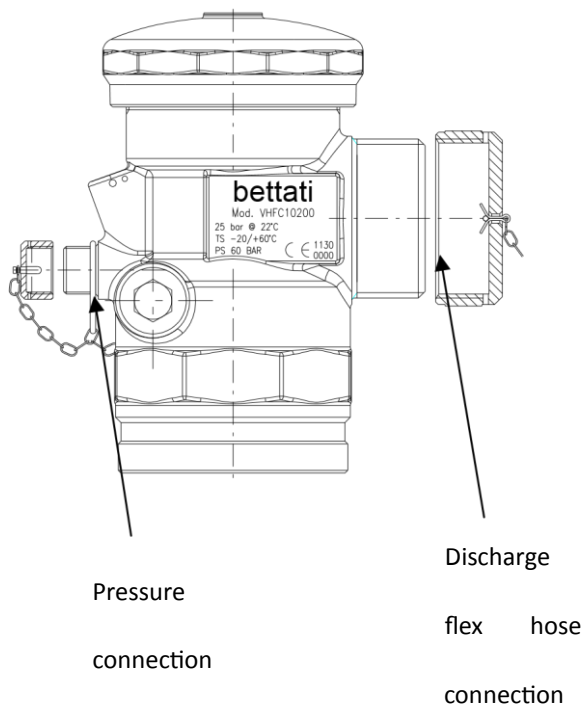
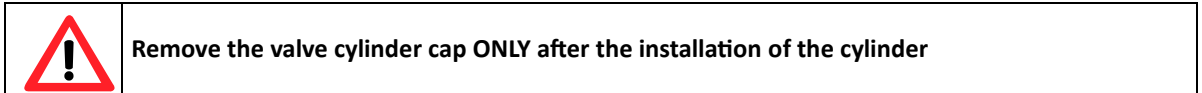

Figure 3.11 Valve connection



Figure 3.12 Discharge flex hose installation

Firstly remove the valve cylinder cap then remove the anti-recoil cap from the valve.

3.4 Discharge manifold installation

Once the cylinders are correctly placed, the next step consists of the installation of the discharge manifold. The discharge manifold collects all gas, contained in the cylinders, and directs it in the piping system in order to permit the discharge by means of the nozzles.



3.4.1 Discharge manifold placement for multiple cylinders system

Fix the bracket supports for the manifold to a wall; the manifold shall be fixed with the proper supplied devices. The manifold is supplied with the non-return valves and it reports a label that certifies the manifold test in conformity with the PED norm.

Once the manifold is placed it is possible to remove the cylinder cap.



The distance between the wall and the manifold axle shall respect the quotes shown in the table.

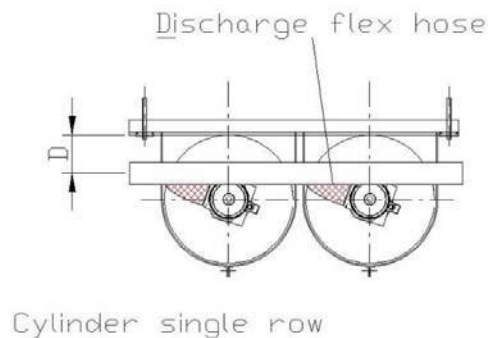

Figure 3.9 Manifold distance from the wall

Cylinder capacity	Distance between lateral wall and axle's manifold; D
75	150 mm
120	150 mm



Figure 3.10 Manifold installation

With the discharge flex hose connect the non-return valve placed on the manifold with the valve outlet. **Particular adjustable non-return valve:** it is possible to adjust the valve length for 20 mm in order to avoid problems caused by the discharge flex hose.



Minimum length (a)



Maximum length (b)

Figure 3.13 Check valve at minimum length (a) and at maximum length (b)

Proceed with the installation of the switch pressure as described in section 2.3.9.

Cylinder capacity		Distance floor manifold mm
75		1790 mm
120 ₁		2240 mm
120 ₂		2280 mm
1	Only for HFC23	
2	Only for HFC227ea e HFC125	



The high of cylinders could be light difference

3.5 Removable pressure gauge with supervisory pressured switch assembly installation

SLAVE CYLINDERS: Remove the antirecoil cap of the pressurized connection and manually install the removable pressure gauge with supervisory pressured switch: make certain that the nut is tightly secured. The removable pressure gauge with supervisory pressured switch will indicate the operating pressure reported on the cylinder label. With a leak detector check if there are any gas leaks from the connections.

 **The plug unscrewing could give rise to slight gas leak; this leak DON'T harm the total pressure of the cylinder, however it's better do this procedure as fast as possible**

Once
the
group



fixed the correct gauge orientation, with an $\varnothing 22\text{mm}$ spanner screw the pressure gauge getting sure complete lock of the

With a



leak detector check if there are any gas leaks from the connections. This checking must be done very carefully.

Figure 3.14 Leak detection

In the figure below are shown the main point in which the leakages can occur.

Slave 75 and 120 l cylinders.

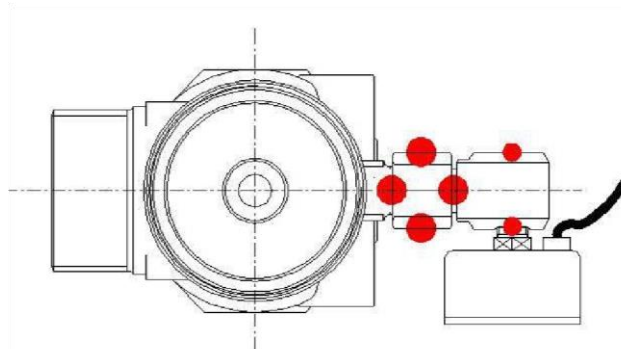

Figure 3.15 The leakages can occur in the red points

3.6 Electrical/manual solenoid actuator installation and pneumatic connection

SYNGLE CYLINDER: Remove the protection cap of the pressurized connection and manually install the actuator (making sure the solenoid is not energized): make certain that the nut is tightly secured. The removable pressure gauge with supervisory pressured switch will indicate the operating pressure reported on the cylinder label. With a leak detector check if there are any gas leaks from the connections.

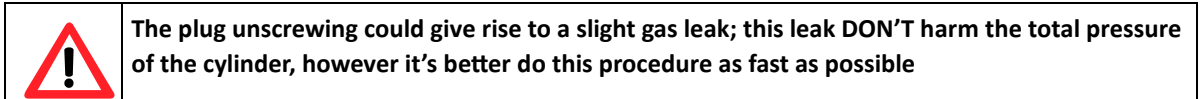

Figure 3.16 Leak detection

Once fixed the correct gauge orientation, with an $\varnothing 22\text{mm}$ spanner screw the pressure gauge getting sure the complete lock of the group



The pressure gauge indicates the cylinder pressure



With a leak detector check if there are any gas leaks from the connections. This checking must be done very carefully.



In the figure below are shown the main point in which the leakages can occur.

Single 14 l and/or 27 l cylinder.

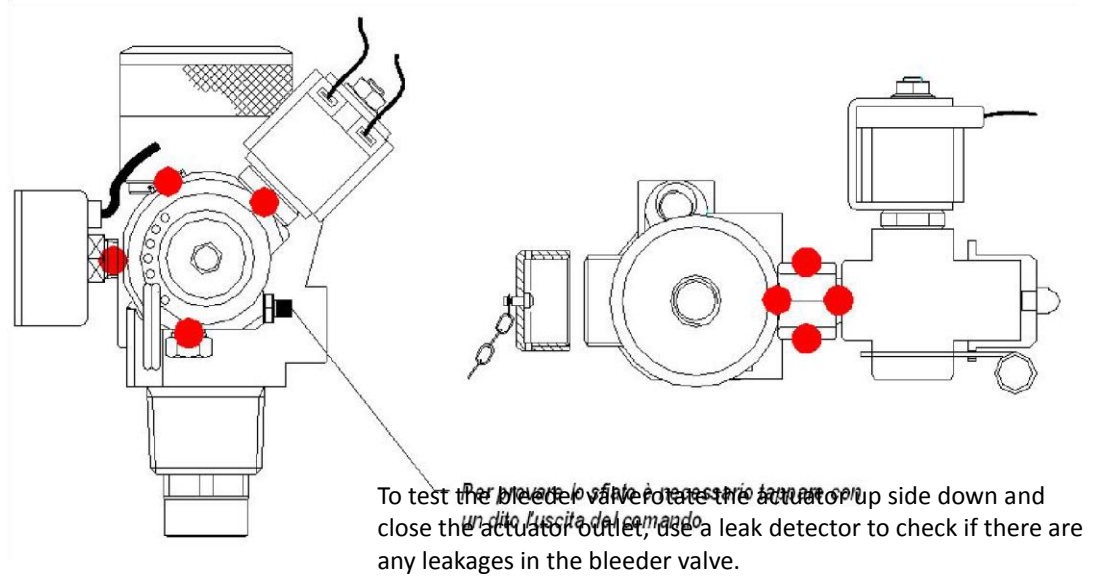

Figure 3.17 The leakages can occur in the red points

Single 50, 75 and 120 l cylinders.

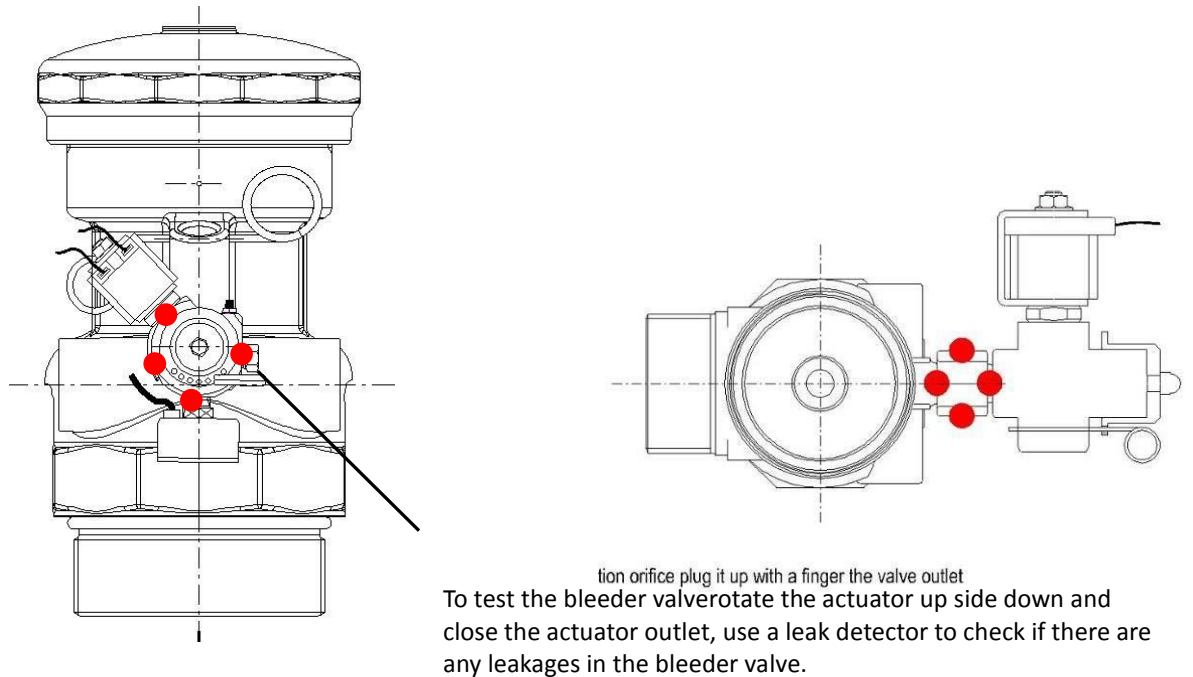
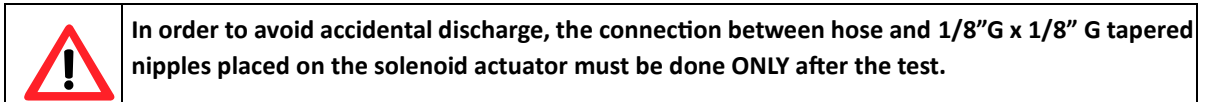

Figure 3.18 The leakages can occur in the red points

3.7 Pilot pneumatic connection

3.7.1 Single cylinder



SINGLE CYLINDER: Screw the 1/4" NPT x 1/4" GAS elbow on the top of the pilot valve and with the flex hose L=400mm connect it with the outlet command diam. 1/8" G x 1/8" tapered thread.

Be careful with the placement of the elbow on the top of the valve, the thread are different (1/4" NPT on the valve e 1/4" gas on the flex hose).

Single 14 l and/or 27 l cylinder.

Single 50, 75 and 120 l cylinders.

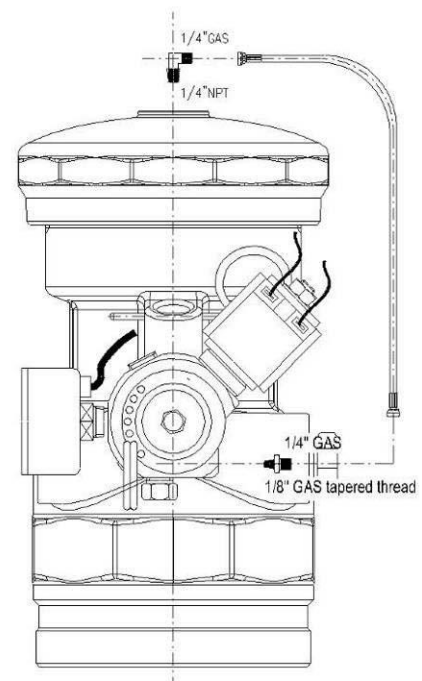
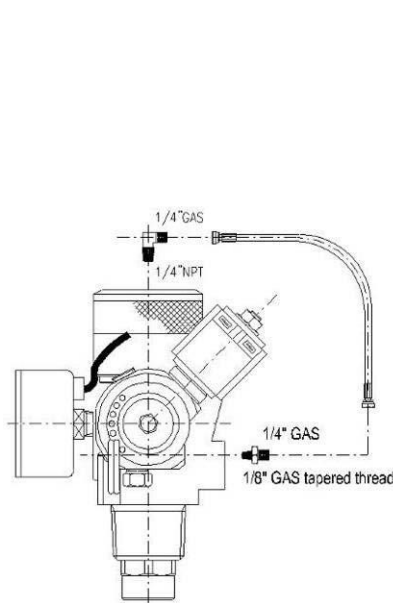
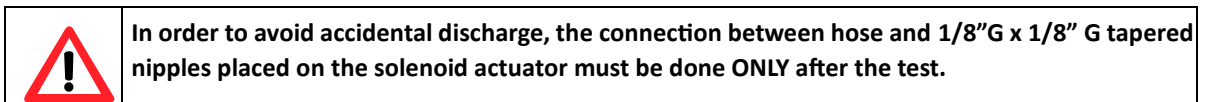

Figure 3.20 Pilot pneumatic connection pilot cylinders



3.7.2 Pilot and slave Cylinder

PILOT CYLINDER: Screw the 1/4" GAS x 1/4" NPT x 1/4" GAS Tee on the top of the pilot valve and with the flex hose L=400mm connect it with the outlet command diam. 1/8" G x 1/8" tapered thread (fig.16).

Be careful with the placement of the elbow on the top of the valve, the thread are different (1/4" NPT on the valve e 1/4" gas on the flex hose).

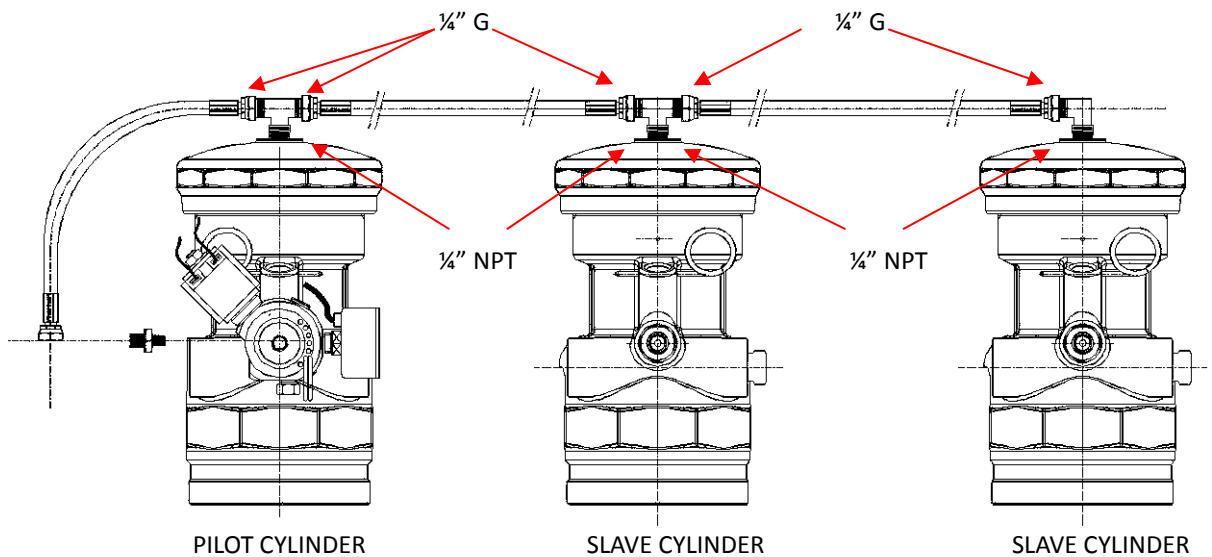

Figure 3.21 Pilot pneumatic connection slave cylinders

Screw the 1/4" Tee on all the slave valve except the last one where the 1/4" elbow shall be placed.

Be careful with the placement of the elbow on the top of the valve, the thread are different (1/4" NPT on the valve e 1/4" gas on the flex hose). With the flex hose L=500mm connect all valves.



Figure 3.22 Pilot pneumatic connection

4 Pipes, fittings, brackets and nozzles installation



Due to the large variety of brackets and support devices existing on sale, we can choose different solution for particular application for the pipes installation.

On the basis of the pipes path shown on the technical drawings, it shall be chosen the proper bracket models and the proper raw plugs, and check if they are able to support the loads

The UNI ISO 15004 prescribes the maximum brackets distance in according to the pipe diameter.



Figure 4.1 Piping system supports

Pipe diameter	Max. distance (m)
1/2"	1,5
3/4"	1,8
1"	2,1
1"1/4	2,4
1"1/2	2,7
2"	3,4
2"1/2	3,5
3"	3,7

The shall be

The with



Figure 4.2 Piping system fittings

fittings such as elbows, tees, restrictors, nozzles, etc... supplied, unless different specifications, by Bettati Antincendio with a NPT threads.

tight locking between fittings and pipes must be done teflon or other proper material.

Each discharge nozzle has inside an orifice plate with a different diameter.

Additionally each discharge nozzle has got a label where are reported some information:

- Nozzle serial number (i.e. 11001)



bettati UGELLO n. _____ d. _____ mm



www.atapars.com

آدرس سایت:

info@atapars.com

آدرس پست الکترونیکی:

+۹۸۲۱ - ۹۱۰۹۲۰۷۶

تلفن دفتر مرکزی:

+۹۸۹۳۹۹۶۰۳۸۰۰

تلفن همراه:

آبادگستر تاسیسات ایرانیان (آتا)
Abad Gostar Tasisat Iranian Co., LTD

- Nozzle diameter (inch)
- Orifice plate diameter (mm)

Be careful during the installation: each nozzle must be placed as describe on the design

5 Mechanical system acceptance document.

5.1 Testing procedures

In the table 5.1 below are summed up all the essential steps to doing correctly the test for the fire-fighting mechanical system

System Location

Table 5.1 Table for acceptance test

Customer	San Polo D'Enza
System Location	Storical Archives, via Levi, 1 San Polo D'Enza
	First Floors
System Type	Extinguishing halocarbon HFC227EA gas system
Date	11/29/09

Mechanical system specific data

Cylinders characteristics			Extinguishing gas data		TEST EXPIRE DATE
CAPACITY	BRAND	SERIAL NUMBER	TYPE	AMMOUNT (KG)	
120 lt	Xxx	05/8472/001	HFC227EA	///	2015
120 lt	Xxx	05/8472/002	HFC227EA	///	2015
120 lt	Xxx	05/8472/003	HFC227EA	///	2015
120 lt	Xxx	05/8472/003	HFC227EA	///	2015
120 lt	Xxx	05/8472/004	HFC227EA	///	2015

Tests description	RESULT		
Protect area volume acceptance			
Enclosure check	yes	no	na
Review of enclosure integrity	yes	no	na
	yes	no	na



www.atapars.com

آدرس سایت:

info@atapars.com

آدرس پست الکترونیکی:

+۹۸۲۱ - ۹۱۰۹۲۰۷۶

تلفن دفتر مرکزی:

+۹۸۹۳۹۹۶۰۳۸۰۰

تلفن همراه:

آبادگستر تاسیسات ایرانیان (آتا)
Abad Gostar Tasisat Iranian Co., LTD

	Door fan test with: gauge matr.....			
	yes	no	na	
Review of mechanical components	yes	no	na	
Design conformity checking of:	yes	no	na	Cylinders
	yes	no	na	Pipeline
	yes	no	na	Nozzles
Cylinders and pipe fixing checking	yes	no	na	
Devices locking checking – Cylinder, pipeline, nozzle	yes	no	na	
Pneumatic pipeline checking at 3 bar for 10 min (loss of pressure lower than 20%) Done with pressure gauge matr.	yes	no	na	
Pipeline fluxing checking	yes	no	na	
Preliminary functional test	yes	no	na	
Functional test 1 th method				
Functional test 2 nd method	yes	no	na	
Documents	yes	no	na	
System technical report	yes	no	na	
Material safety data sheet (MSDS)				
Hydraulic Calculation				
Working documents				
a) drawings, to an indicated scale of extinguishant distribution system, including containers, location of containers, piping and nozzles, valves and pressure-reducing devices and pipe hanger spacing;	yes	no	na	
b) name of owner and occupant;				
c) location of building in which hazard is located;				
d) location and construction of protected enclosure walls and partitions;				

e) enclosure cross-section, full height or schematic diagram, including raised access floor and suspended ceiling;			
f) type of extinguishant being used;			
g) extinguishing or inerting concentration, design concentration and maximum concentration;			
h) description of occupancies and hazards to be protected against;			
i) specification of containers used, including capacity, storage pressure and mass including extinguishant;			
j) description of nozzle(s) used, including inlet size, orifice port configuration, and orifice size/code and orifice size of pressure-reducing devices, if applicable;			
k) description of pipes, valves and fittings used, including material specifications, grade and pressure rating;			
l) equipment schedule or bill of materials for each piece of equipment or device, showing device name, manufacturer, model or part number, quantity and description;			
m) isometric view of extinguishant distribution system, showing the length and diameter of each pipe segment and node reference numbers relating to the flow calculations; n) enclosure pressurization and venting calculations;			
o) description of fire detection, actuation and control systems.			
CE guideline 97/23/CE's declaration of conformity- Manifold	yes	no	na
CE guideline 97/23/CE's declaration of conformity- System	yes	no	na
Door fan test result	yes	no	na
Cylinders certificate	yes	no	na
CE declaration of conformity- Valves	yes	no	na
User and maintenance manuals	yes	no	na
Testing minutes	yes	no	na

The first part of the table shows the most important data for the fire-fighting system: user, protected area position, system type (i.e. gas type, single cylinder or multiple cylinder systems, etc.) and the testing date.

The second part of the table shows the cylinders data, these information are read from the cylinders labels.

The third part of the table shows the testing did for the system. Each test can be successful or unsuccessful. The mandatory test for the system are listed below:

5.1.1 Protected area volume

Protect area volume acceptance: this data must be in accordance with the design.

5.1.2 Protected area integrity

Protected area integrity acceptance: this test can be done by a own skilled staff.

From the EN 15004:2008 norm:

EN 15004:2 7.8.2: "It is essential to determine the likely period during which the extinguishing concentration will be maintained within the protected enclosure. This is known as the hold time. The predicted hold time shall be determined by the door fan test specified in Annex E, or a full discharge test based on the following criteria:

- at the start of the hold time, the concentration throughout the enclosure shall be the design concentration;
- at the end of the hold time, the extinguishant concentration at 10 %, 50 % and 90 % of the enclosure height shall be not less than 85 % of the design concentration;
- the hold time shall be not less than 10 min, unless otherwise specified by the authority."

Annex E: "Door fan test for determination of minimum hold time"

Door fan integrity test.

Mandatory test in according to EN 15004 norm, that simulates the gas behaviour after a real discharge establishing the integrity of rooms and enclosures with respect to maintaining the extinguishant concentration for the relevant period (hold time).



Figure 5.1 Equipments for door fan integrity test

5.1.3 **Design correspondence**

Check the correspondence between the design (cylinders, pipeline and nozzles placement) and the actual installed system.



Every modification must be communicated to Bettati Antincendio, that shall check the correct system working.

5.1.4 **Pipeline fixing**

Cylinders and manifolds fixing check: They must be done as described in paragraphs 3.2 and 3.3 in this manual.

5.1.5 **Pipeline locking**

Cylinders, pipes, and nozzles locking check: the junction between pipes and threaded fittings must have a multi-layer teflon cover or other material in order to improve the leak tightness.

	<p>The cylinders are pressurized at 42 bar; during the discharge the vibrations suffer by the cylinder are considerable; a missing check could cause serius danger to things and people.</p>
	<p>The nozzles and pipes gasses are pressurized from 35 to 15 bar, during the discharge the vibrations or the surge pressures could be very dangerous, a missing check could cause serius danger to things and people.</p>

5.1.6 **Pneumatic circuit**

Pneumatic circuit checking

Any gas leakage must not be present in any point of the pneumatic circuit that could compromise the system functioning.

To do this test it is necessary being equipped with:

- charged nitrogen cylinder;
- pressure reducing device set at 5 bar; • leak detector.

PROCEDURE:

1. Disconnect the flex hose L=400 mm from the solenoid actuator outlet;
2. Connect the flex hose (L=400 mm) to the pressure reducing device placed on the your own nitrogen cylinder;
3. Set the pressure reducing device at 4-5 bar on the outlet and pressurize the circuit;

4. With the leak detector check if the are not gas leak in any point of the circuit connection.

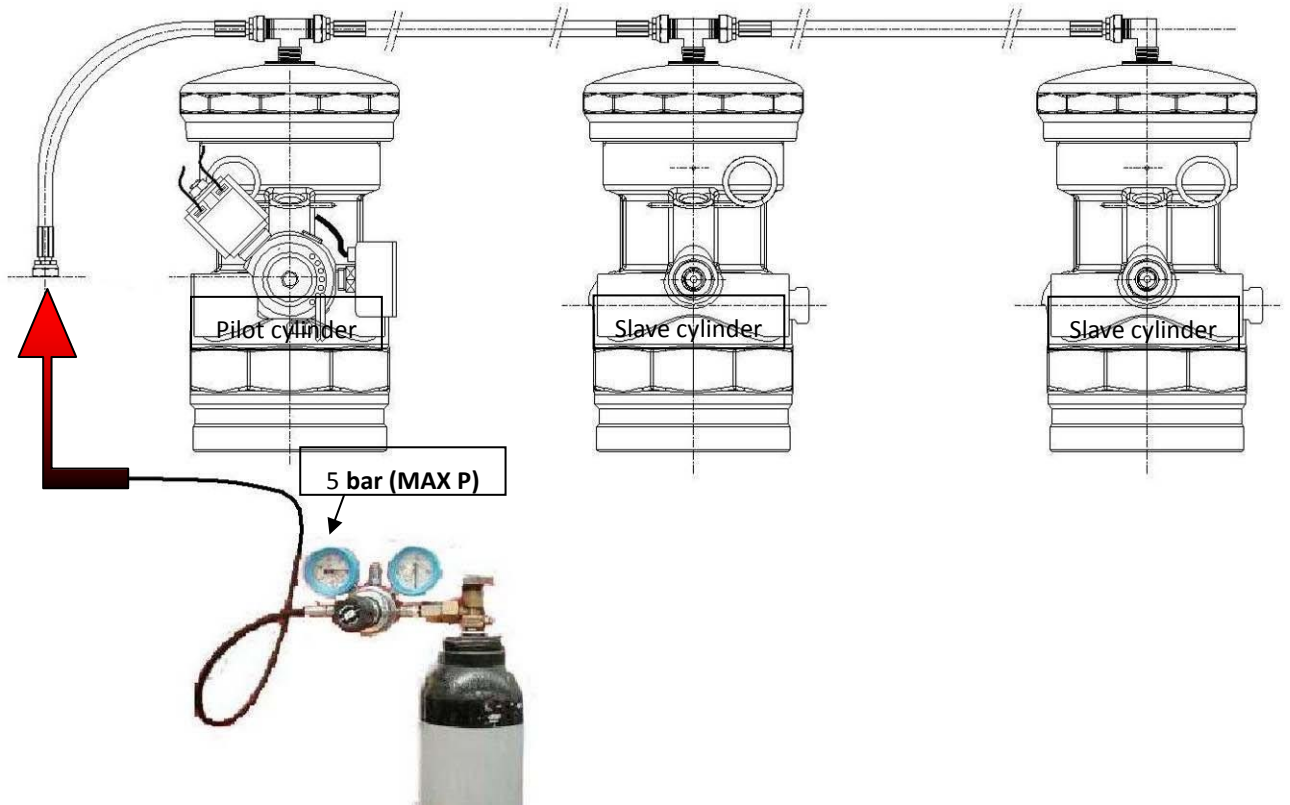

Figure 5.2 Pneumatic circuit test, step 1,2 and 3



During the test be careful to not exceed 4-5 bar, higher pressure could cause the valve cylinders opening



Figure 5.3 Pneumatic circuit test, step 4

5.1.7 Functional Test

Functional test of the fire-fighting system: it could be done in different ways.

The aim of the blank test is to check the good state of the functioning of the system automatism without discharge actually the extinguishing gas.

FIRST METHOD

1. Dismount the solenoid valve placed on the pilot cylinder unscrewing the nut M10 (fig.19).

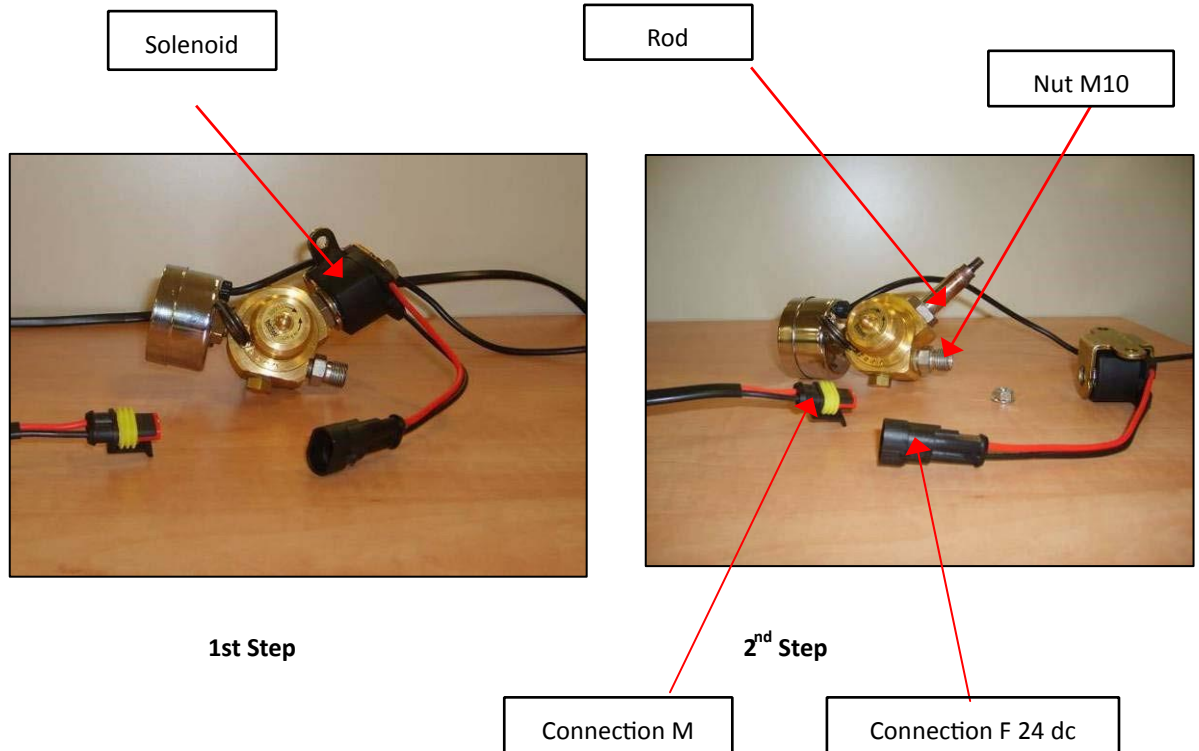

Figure 5.4 Blank test, coil disconnection



Insert a metallic body (e.g. screwdriver) inside the coil and activate the discharge button (placed on the detector panel and/or the remote one) checking the coil excitation. Once that the coil will be energized, the metallic body should be attracted by the magnetic field. Restore the initial conditions to the solenoid actuator (fig.20).



Figure 5.5 Blank test, coil test

SECOND METHOD

With this method we simulate the actual actuation of the solenoid assembly

	This test shall be done ONLY by recommended Bettati Antincendio trained technician
	This test must be done only for cylinder with a capacity of 50,75 or 120 L
	This test must NOT be done for cylinder with a capacity of 14 and 27 L

1. Remove the safety pin (1)
2. Screw the screw for open/close pressure connection (2) in order to isolate the solenoid and to not permit at the gas to flow out;
3. Disconnect the pilot flex hose (3) from the head of the valve (5);
4. Activate the coil of the solenoid actuator (4) connecting the wires red/black to the battery poles or activating the detection panel;
5. Check if the solenoid works correctly permitting the gas flowing in the flex hose;
6. Reconnect the flex hose (3) in the valve head;
7. Check if there are any leakages in the connection of the solenoid;
8. Unscrew the screw for open/close pressure connection (2) in order to restore the initial state;
9. Restore the safety pin (1) and reconnect the pilot flex hose (3) to the elbow (5);
10. Check if there are any leakages in the connection of the solenoid as shown in figure.

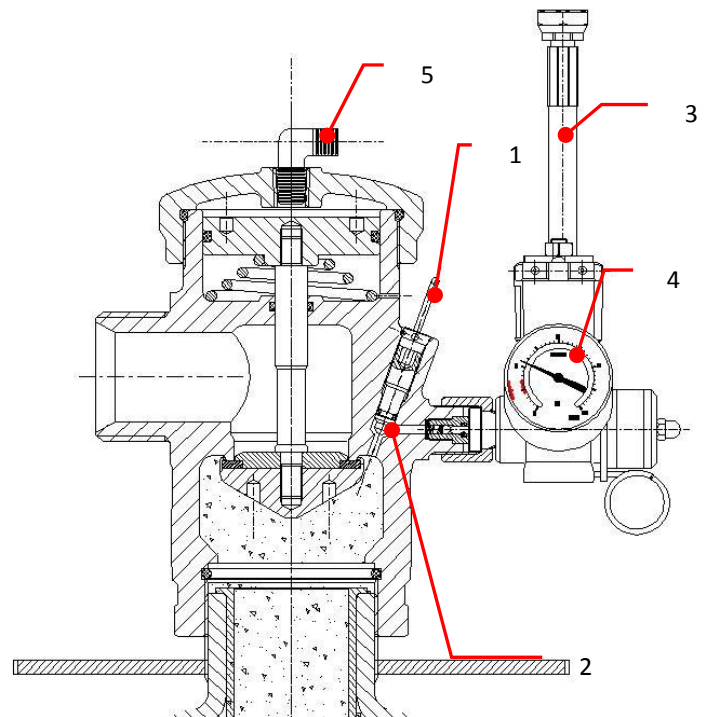

Figure 5.5 Blank test, system description

To test the bleeder valve rotate the actuator up side down and close the actuator outlet, use a leak detector to check if there are any leakages in the bleeder valve (6).

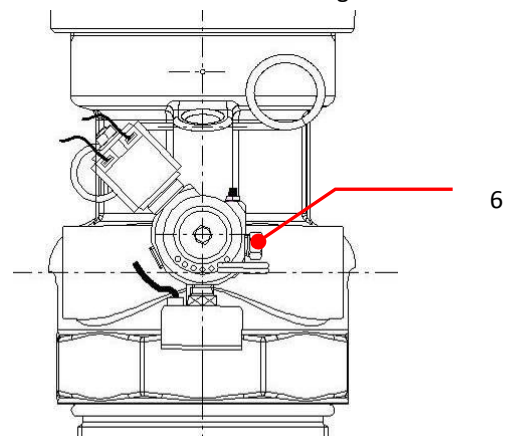

Figure 5.6 Blank test, bleeder valve test

6 Extinguishing system start up

6.1 Electrical-Mechanical connection Solenoid Actuator

After a complete checking of the correct functioning of the detector and extinguishing systems, it is possible go on with the system start up.



Connect the flex hose placed on the top of the pilot cylinder to the nipple of the actuator

Figure 6.1 Flex hose connection



Make sure that circuit is not connected to the power supply and that the solenoid is not energized

Connect electrically the solenoid actuator as shown in the pictures below

STEP A



STEP B



Figure 6.2 Electrical connection

